

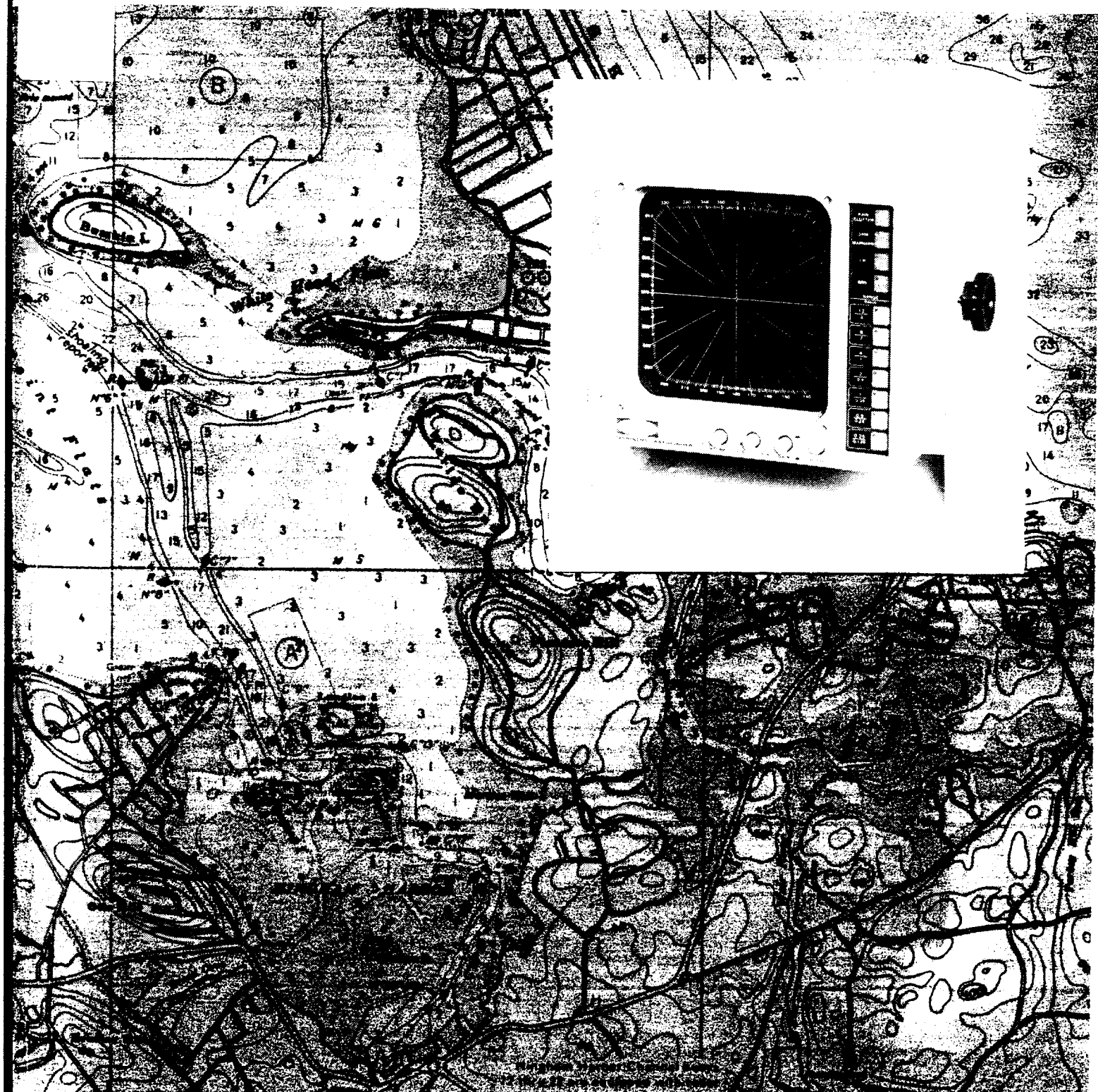

Mariners Pathfinder[®] Radar
Model 1200
Instruction Manual



PURPOSE

**THIS MANUAL CONTAINS IMPORTANT INFORMATION OF THE INSTALLATION
OPERATION AND MAINTENANCE OF YOUR EQUIPMENT**

RAYTHEON MARINE COMPANY products are supported by a network of Authorized Service Representative to you location you may contact the following regional centers:

Western United States Raytheon Marine Company
20410 Gramercy Place
Torrance, CA 90501
Phone: 800-862-5555
(In CA: 800-842-3333)

Eastern United States Raytheon Marine Company
676 Island Pond Road
Manchester, NH 03103
Phone: 603-668-1600

Europe Rayscan Copenhagen
Siljengade 6 DK2300
Copenhagen S Denmark
Phone: 451-570611

Far East Raytheon Marine Sales & Service Co.
Minato-Ise Building 3-12-1
Kaigandori Naka-ku
Yokohama, Japan 231
Phone: 045-212-3633

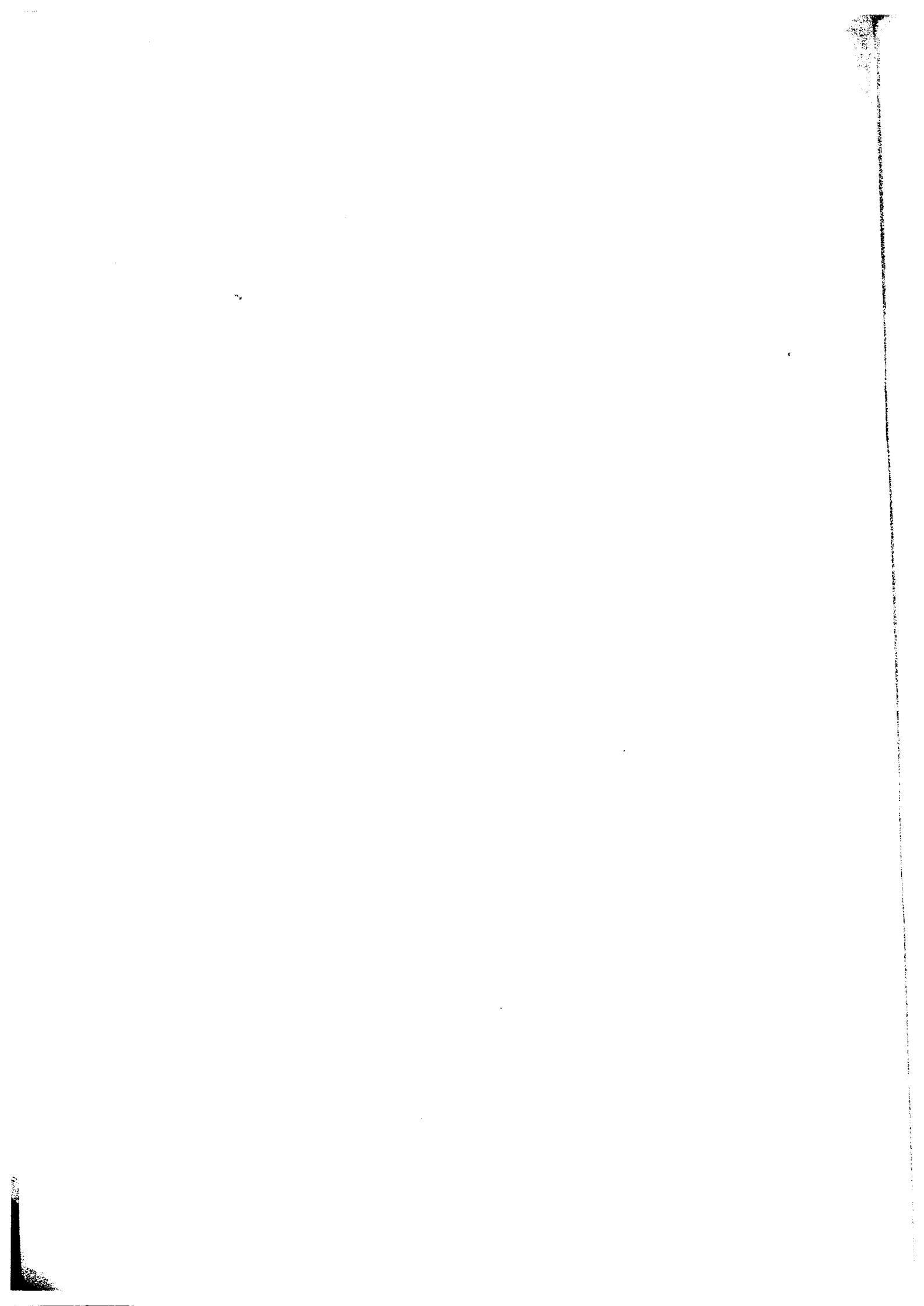

HIGH VOLTAGE WARNING

Do not open any of the units when the radar is ON; high voltages within the Scanner and Display Unit could be fatal to anyone coming in direct contact with them.

Disconnect ship's power from the Scanner and Display Unit before attempting any maintenance; otherwise, ship's power will be present at terminals inside the Scanner and Display Unit.

RADIATION HAZARD

Care should be taken to avoid possible harmful effects (particularly to the eyes) of radiation from radar transmissions.

To avoid harmful radiation, the Display OPERATE switch should be turned to the STBY or OFF position when working on the Scanner. Under no circumstances should you look directly into the antenna from a distance of less than 2 feet when the radar is in operation.

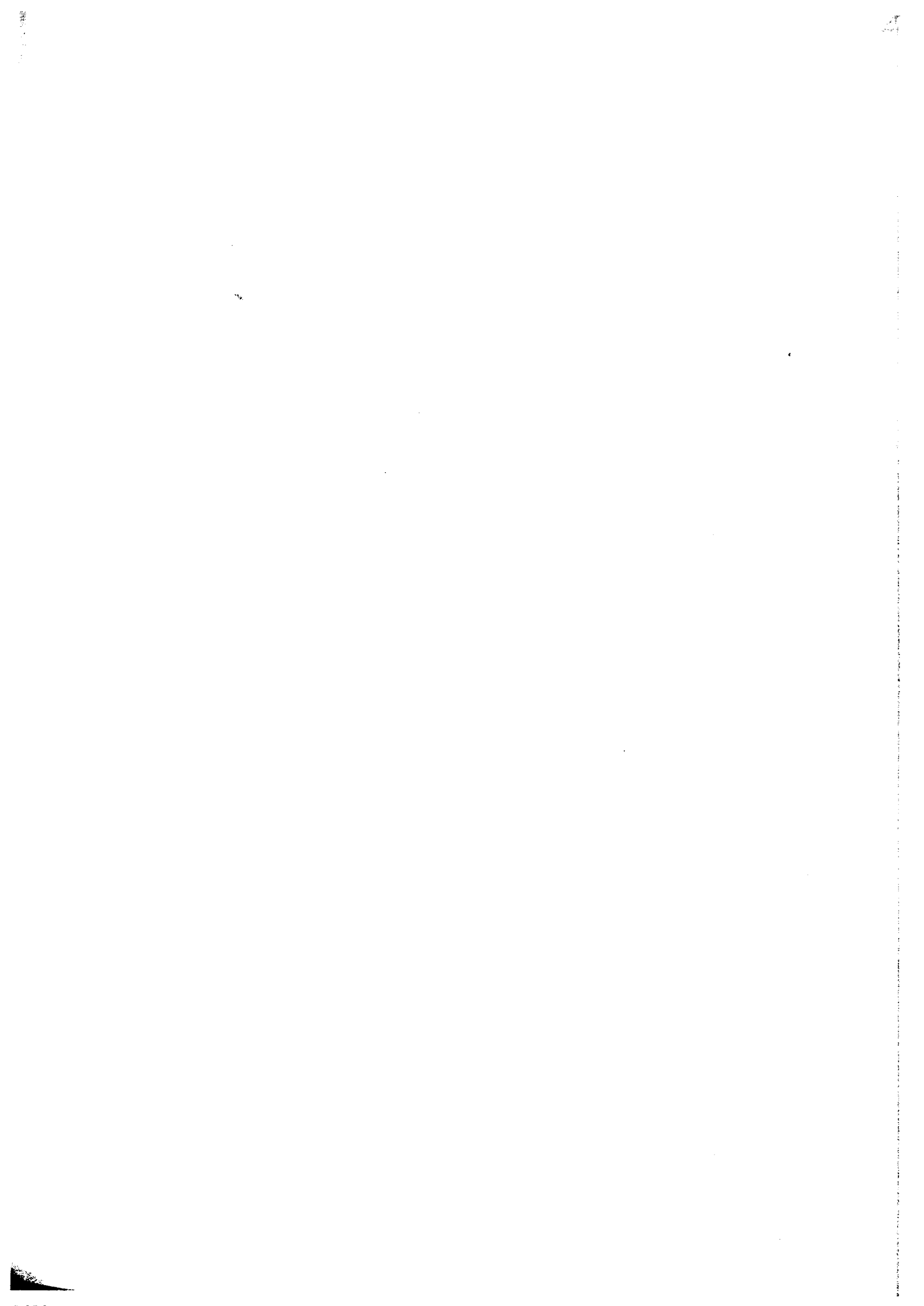

CONTENTS

SECTION 1. GENERAL DESCRIPTION	1-1
1.1 INTRODUCTION	1-1
1.2 PHYSICAL DESCRIPTION	1-2
1.3 SPECIFICATIONS	1-4
SECTION 2. OPERATION	2-1
2.1 OPERATING CONTROLS	2-1
2.2 RANGE AND BEARING MEASUREMENTS	2-4
2.3 USING THE CONTROLS	2-5
2.4 NAVIGATION WITH THE RADAR	2-6
2.5 FALSE ECHOES	2-9
SECTION 3. MAINTENANCE	3-1
3.1 GENERAL	3-1
3.2 SCANNER UNIT	3-1
3.3 DISPLAY UNIT	3-1
SECTION 4. INSTALLATION	4-1
4.1 PLANNING	4-1
4.2 INSTALLATION OF SCANNER UNIT	4-2
4.3 INSTALLATION OF DISPLAY UNIT	4-4
4.4 CHANGE ARRANGEMENT FOR SHIP'S MAINS INPUT	4-5
4.5 CABLE INFORMATION	4-6
4.6 INITIAL OPERATION AND CHECKOUT	4-8
SECTION 5. ADJUSTMENT AND FAULT FINDING	5-1
5.1 ADJUSTMENT	5-1
5.2 TROUBLE-SHOOTING	5-6
5.3 REPLACEMENT OF MAJOR COMPONENTS	5-14
SECTION 6. TECHNICAL DESCRIPTION	6-2
6.1 BLOCK DIAGRAM DESCRIPTION	6-2
6.2 SCANNER UNIT	6-9
6.3 DISPLAY UNIT	6-15
SECTION 7. PARTS LIST	7- 1

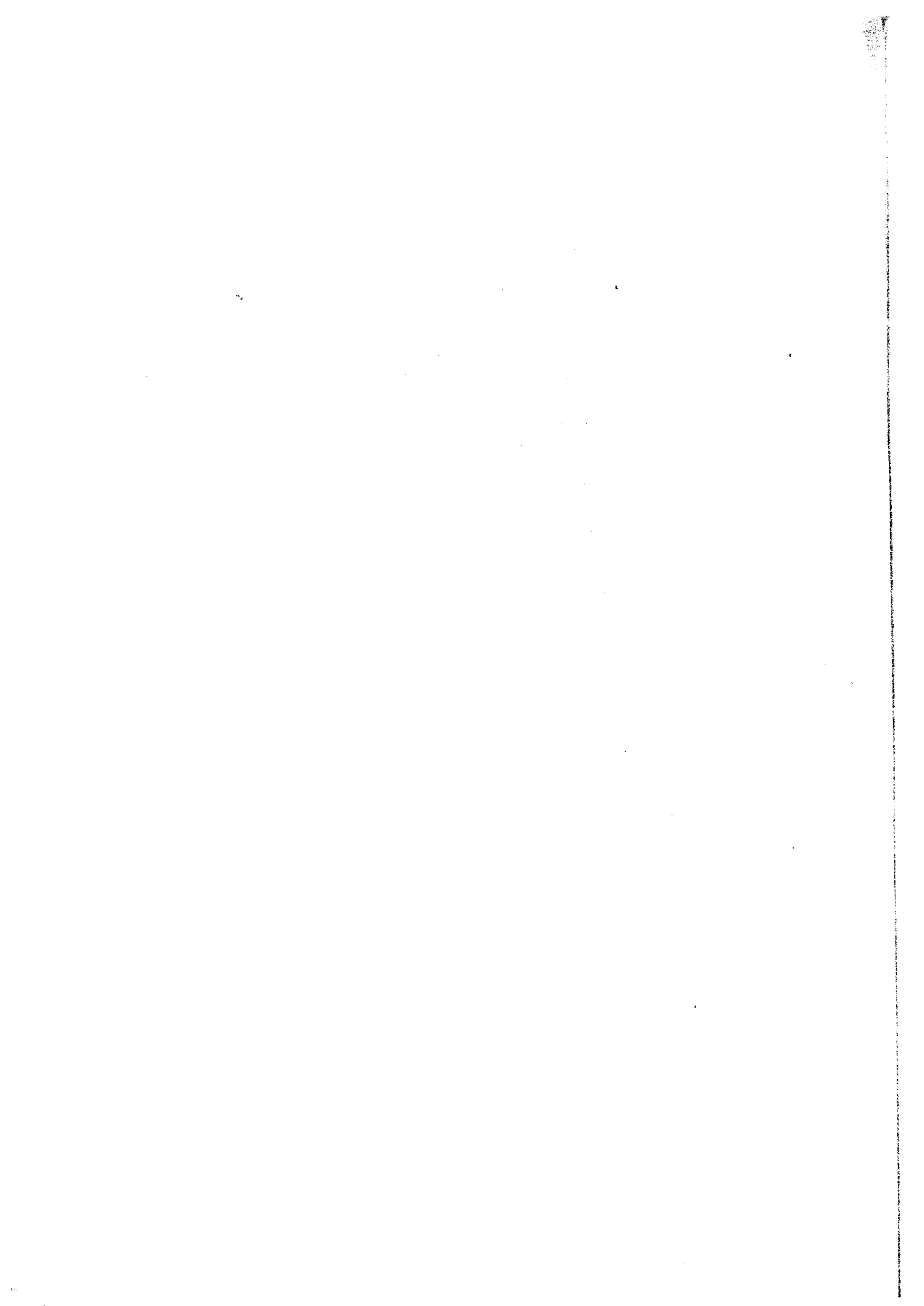

DRAWINGS

Figure	Title
101	GENERAL SYSTEM OF 1200 RADAR
102	OUTLINE DRAWING OF M89362 SCANNER UNIT
103	OUTLINE DRAWING OF M89361 DISPLAY UNIT
104	BLOCK DIAGRAM OF 1200 RADAR
105	INTERCONNECTIONS OF 1200 RADAR
106	POWER SUPPLY DIAGRAM OF 1200 RADAR
107	CIRCUIT DRAWING OF M89362 SCANNER UNIT
108	INTERNAL CONNECTION OF M89361 DISPLAY UNIT
109	CIRCUIT DRAWING OF MAIN CONTROL PCB BUILT-IN DISPLAY UNIT
110	CIRCUIT DRAWING OF CONTROL PANEL PCB BUILT-IN DISPLAY UNIT
111	CIRCUIT DRAWING OF DISPLAY ASSEMBLY BUILT-IN DISPLAY UNIT
112	CIRCUIT DRAWING OF POWER SUPPLY PCB BUILT-IN DISPLAY UNIT
113	ASSEMBLY DRAWING OF M89362 SCANNER UNIT
114	ASSEMBLY DRAWING OF M89361 DISPLAY UNIT

SECTION 1

GENERAL DESCRIPTION

1.1 INTRODUCTION

Congratulations on selecting the Raytheon Model 1200 Mariners Pathfinder Radar for your radar navigation needs.

Whether you purchased this radar because of its compactness or power economy, ease of installation, or long term reliability, one thing is certain; the moment you turn on your 1200 you'll know you're seeing a revolutionary new concept in radar technology at work.

Radar signals are "stored" on a 9-inch diagonal TV-type picture with chart like clarity and detail. A single glance at your Model 1200 Display will give you a complete and accurate 360° radar picture of other vessels, bouys and land fall surrounding your vessel.

A unique feature even allows you to "freeze" the picture for high accuracy bearing and range measurements.

With "one touch" range selection, recessable controls, and "Interference Rejection", (a feature found only on bigger-radar systems) it should become apparent that human engineering and operational simplicity have been considered foremost in the 1200's design.

We trust that you will enjoy many years of excellent performance, reliability, and smooth sailing with your new 1200 Radar.

1.2 PHYSICAL DESCRIPTION

1.2.1 Scanner Unit

The antenna and transceiver are combined within the 24½ inch radome which is made of AES plastic and has a single-flange mounting. A small, flexible cable connects the Scanner Unit to the Display Unit. The radome cover is secured to the scanner pan base by four clamping bolts and provided with a rubber gasket to seal the unit from the weather and salt spray.

1.2.2 Display Unit

The Display Unit is enclosed in a drip-proof case and can be easily mounted on top of a chart table, installed against a bulkhead, or hung from the overhead. All controls for operating the 1200 Radar are located on the front panel and positioned to easy adjustment during day or night use. A bearing scale is illuminated around the screen, and is used to determine the relative bearing to a target.

The compact transistor inverter, housed within the Display Unit, converts the ship's mains supply (12, 24, or 32 Vdc) to the power supply voltages required by the radar system.

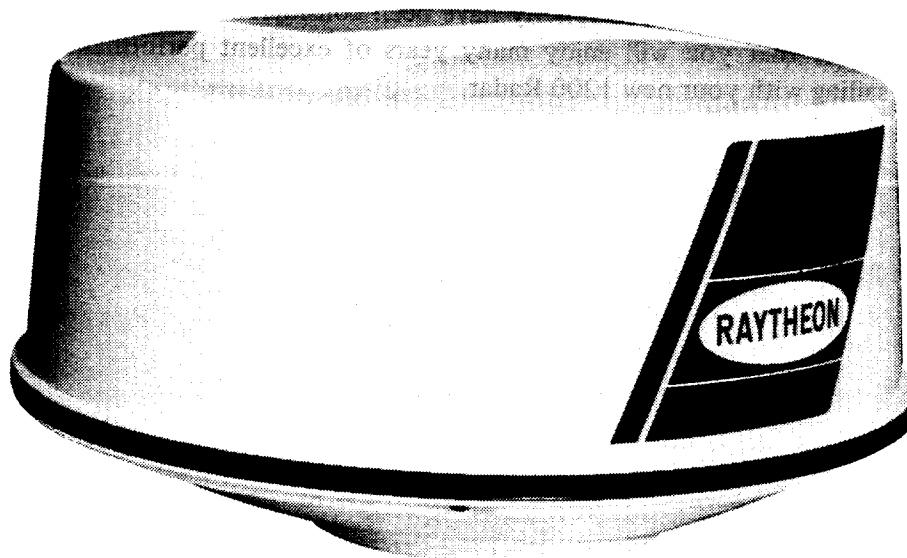

SCANNER UNIT

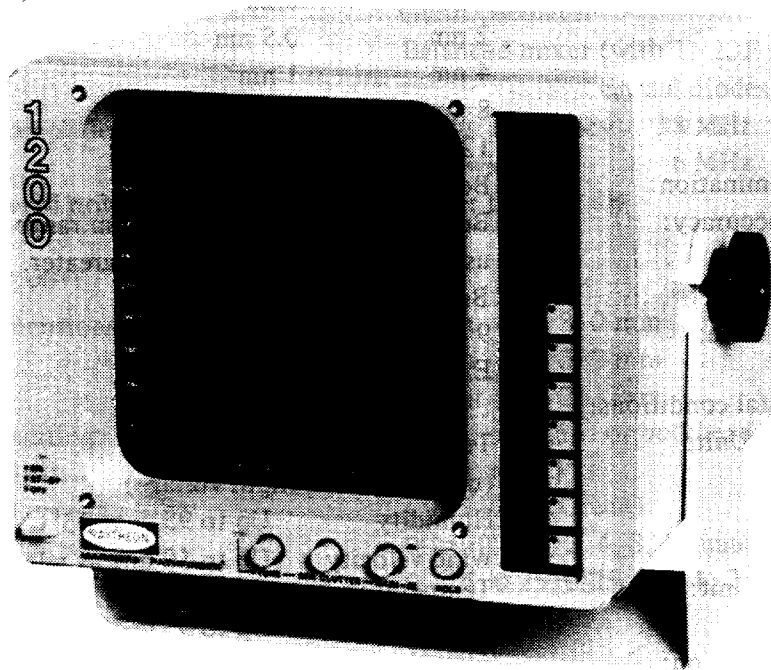

DISPLAY UNIT

1.3 SPECIFICATIONS

1.3.1 General

- | 1) Maximum range: | 12 nautical miles. | | | | | | | | | | | | | | | | | | | | | | | | |
|------------------------------------|---|-----------------|---------------------|-----------------|---------|----------|---|--------|---------|---|------|---------|---|------|--------|---|------|------|---|------|------|---|-------|------|---|
| 2) Minimum range: | Better than 32 m on 0.25 n.m. | | | | | | | | | | | | | | | | | | | | | | | | |
| 3) Range Scales: | <table border="0"> <thead> <tr> <th>Range</th> <th>Range ring interval</th> <th>Number of rings</th> </tr> </thead> <tbody> <tr> <td>0.25 nm</td> <td>0.125 nm</td> <td>2</td> </tr> <tr> <td>0.5 nm</td> <td>0.25 nm</td> <td>2</td> </tr> <tr> <td>1 nm</td> <td>0.25 nm</td> <td>4</td> </tr> <tr> <td>2 nm</td> <td>0.5 nm</td> <td>4</td> </tr> <tr> <td>4 nm</td> <td>1 nm</td> <td>4</td> </tr> <tr> <td>8 nm</td> <td>2 nm</td> <td>4</td> </tr> <tr> <td>12 nm</td> <td>3 nm</td> <td>4</td> </tr> </tbody> </table> | Range | Range ring interval | Number of rings | 0.25 nm | 0.125 nm | 2 | 0.5 nm | 0.25 nm | 2 | 1 nm | 0.25 nm | 4 | 2 nm | 0.5 nm | 4 | 4 nm | 1 nm | 4 | 8 nm | 2 nm | 4 | 12 nm | 3 nm | 4 |
| Range | Range ring interval | Number of rings | | | | | | | | | | | | | | | | | | | | | | | |
| 0.25 nm | 0.125 nm | 2 | | | | | | | | | | | | | | | | | | | | | | | |
| 0.5 nm | 0.25 nm | 2 | | | | | | | | | | | | | | | | | | | | | | | |
| 1 nm | 0.25 nm | 4 | | | | | | | | | | | | | | | | | | | | | | | |
| 2 nm | 0.5 nm | 4 | | | | | | | | | | | | | | | | | | | | | | | |
| 4 nm | 1 nm | 4 | | | | | | | | | | | | | | | | | | | | | | | |
| 8 nm | 2 nm | 4 | | | | | | | | | | | | | | | | | | | | | | | |
| 12 nm | 3 nm | 4 | | | | | | | | | | | | | | | | | | | | | | | |
| 4) Range discrimination: | Better than 22 m. | | | | | | | | | | | | | | | | | | | | | | | | |
| 5) Range ring accuracy: | Better than $\pm 2.5\%$ of maximum range of the scale in use, or 22 m, whichever is the greater. | | | | | | | | | | | | | | | | | | | | | | | | |
| 6) Bearing accuracy: | Better than ± 1 degree. | | | | | | | | | | | | | | | | | | | | | | | | |
| 7) Cathode-ray tube: | 9 in. tube.
Effective diameter 130 mm | | | | | | | | | | | | | | | | | | | | | | | | |
| 8) Environmental conditions: | | | | | | | | | | | | | | | | | | | | | | | | | |
| Scanner Unit: | Temperature -15°C to $+50^{\circ}\text{C}$
(under nominal input voltage)
Humidity Up to 95 % at 35°C
Wind velocity Up to 50 m/s as relative
Temperature -10°C to $+50^{\circ}\text{C}$
Humidity Up to 95 % at 35°C | | | | | | | | | | | | | | | | | | | | | | | | |
| Display Unit: | | | | | | | | | | | | | | | | | | | | | | | | | |
| 9) Power Consumption: | | | | | | | | | | | | | | | | | | | | | | | | | |
| DC 12V: | 4.5A | | | | | | | | | | | | | | | | | | | | | | | | |
| DC 24V: | 2.3A | | | | | | | | | | | | | | | | | | | | | | | | |
| DC 32V: | 1.8A | | | | | | | | | | | | | | | | | | | | | | | | |
| 10) Ship's mains voltage variation | | | | | | | | | | | | | | | | | | | | | | | | | |
| DC 12V: | 11V ~ 16V | | | | | | | | | | | | | | | | | | | | | | | | |
| DC 24V: | 22V ~ 32V | | | | | | | | | | | | | | | | | | | | | | | | |
| DC 32V: | 28V ~ 42V | | | | | | | | | | | | | | | | | | | | | | | | |

1.3.2 Scanner Unit

- | | |
|-------------------------------|---|
| 1) Dimensions: | Diameter of radome 620 mm
Height 345 mm |
| 2) Weight | Approx. 9.5 kg |
| 3) Polarization: | Horizontal |
| 4) Beam width: | Horizontal 5°
Vertical 25° |
| 5) Sidelobes: | Better than -21 dB |
| 6) Rotation: | Approx. 27 RPM |
| 7) Drive motor input voltage: | DC 12V |
| 8) Transmitter frequency: | 9445 ± 30 MHz |

- 9) Peak power output: 3 kw
- 10) Transmitter tube: Magnetron (M1315)
- 11) Pulse length/Pulse repetition frequency: 0.12 μ s/920 Hz (0.25, 0.5, 1, 2 nm)
0.5 μ s/920 Hz (4, 8, 12 nm)
- 12) Modulator: Solidstate modulator driving magnetron
- 13) Duplexer: Circulator
- 14) X'tal protector: Diode Limiter
- 15) Local oscillator: Gunn Oscillator
- 16) Mixer: Balanced mixer (with 1N23E and 1N23ER crystal diodes)
- 17) IF amplifier: Center frequency 38 MHz
Bandwidth 6 MHz
- 18) Overall noise figure: Better than 10 dB

1.3.3 DISPLAY UNIT

- 1) Dimensions: Width 310 mm
Depth 380 mm
Height 263 mm
- 2) Mounting: Table, overhead or bulkhead mounting
- 3) Weight: Approx. 7.5 kg
- 4) Cathode-ray tube: C935 P31 (Green)
- 5) Range scales: 0.25, 0.5, 1, 2, 4, 8, 12 nautical miles
- 6) Range rings: 0.125, 0.25, 0.25, 0.5, 1, 2, 3 nautical miles
- 7) Bearing synchronizing system: Motor Encoder
- 8) Tuning: Manual
- 9) Bearing scale: 360° scale graduated at intervals of 1°
- 10) Ship's heading marker: Electrical
- 11) Controls: OPERATE (OFF-STBY-ON)
TUNE
SEA-CLUTTER
GAIN
HOLD (SW)
RAIN CLUTTER (SW)
SHM, MARKERS (SW)
IR (SW)
BRIL (SW)
RANGE (0.25, 0.5, 1, 2, 4, 8, 12)

1.3.4 Inter-Unit Cable Length

	Type of Cable	Standard Length	Maximum Length
Scanner-Display	H-2695110006	10 m	20 m

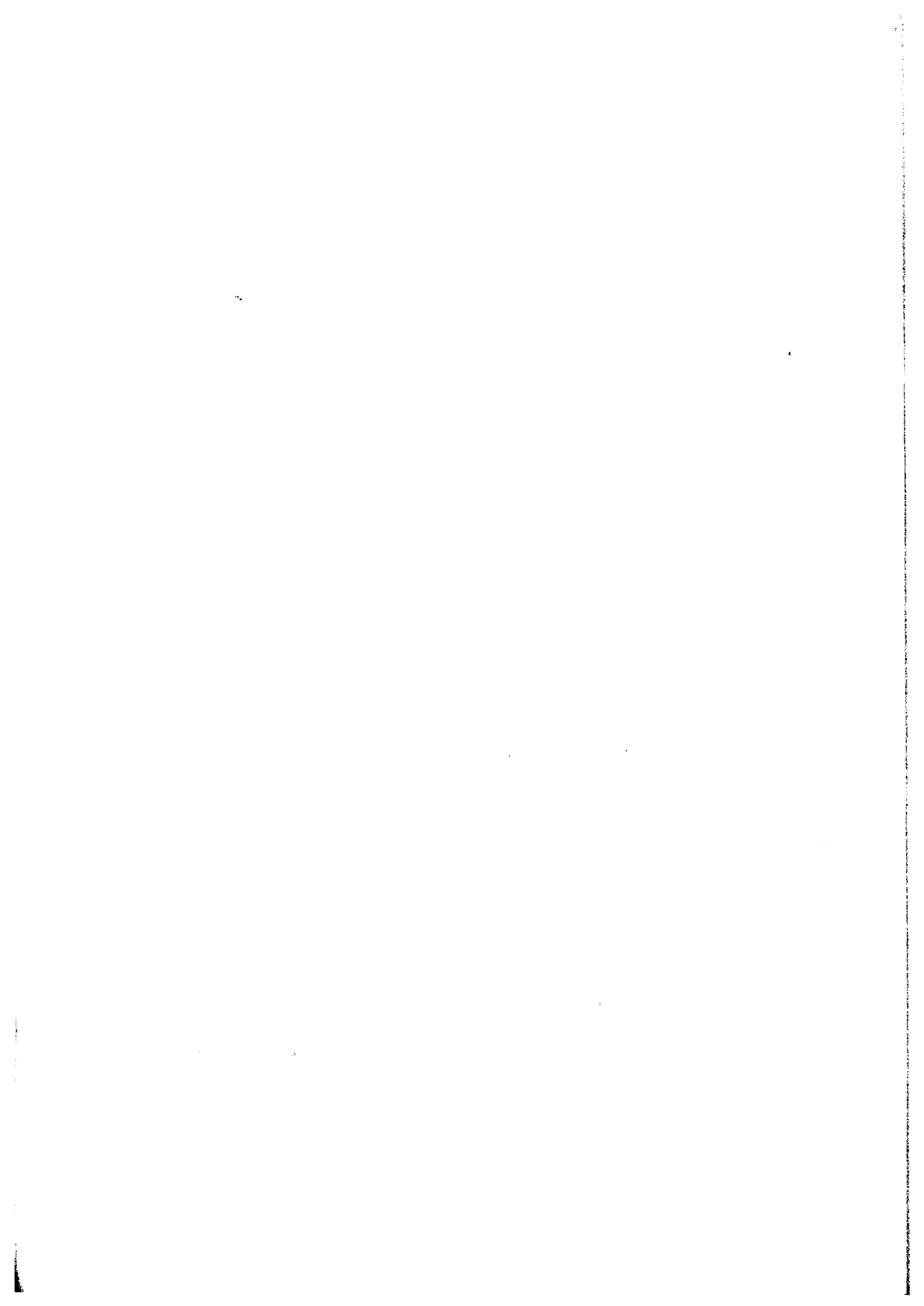

SECTION 2

OPERATION

2.1 OPERATING CONTROLS

Generally the operation of the 1200 is easy and straight forward. However, the navigator who knows the layout and understands the functions of the various controls will obtain the best performance from his equipment.

2.1.1 Layout of the Controls

Layout of the controls is shown in Figure 2-1.

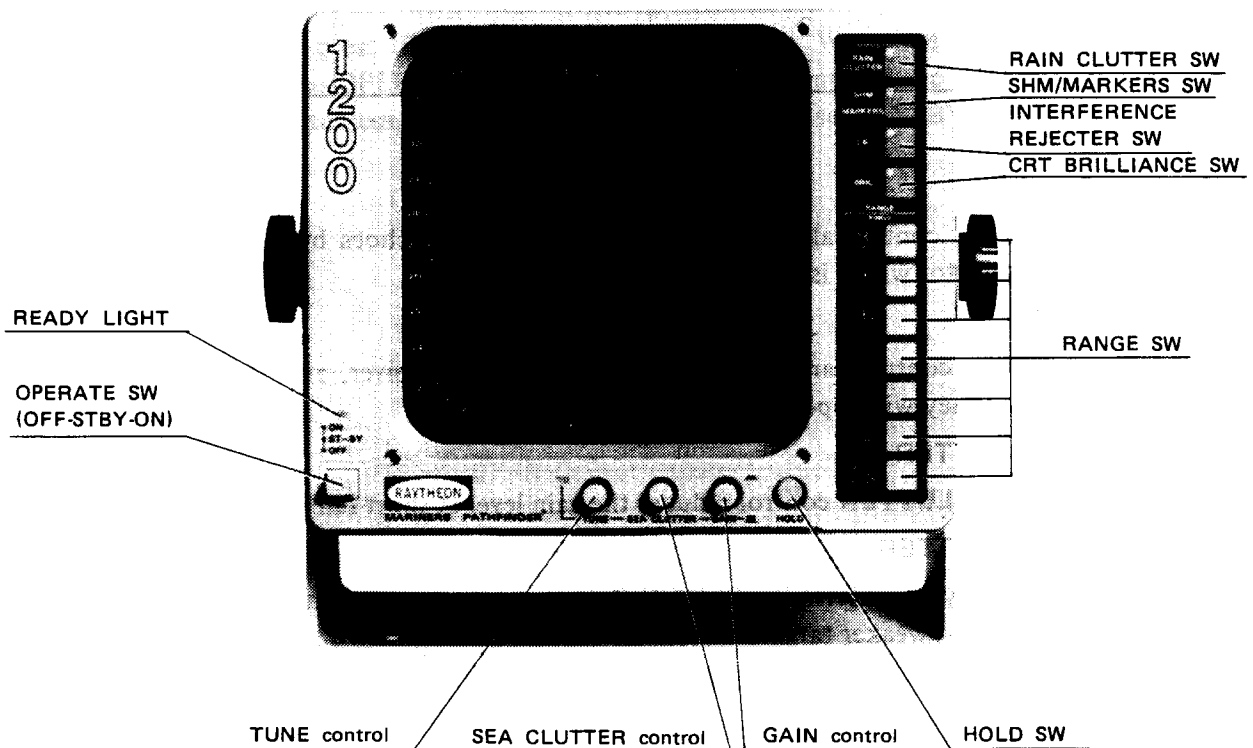

FIG. 2-1 OPERATING CONTROLS

2.1.2 Function of the Controls

1) OPERATE (OFF-STBY-ON)

In OFF position there is no power supplied to the Scanner Unit and Display Unit. In STBY position, power is supplied to the Scanner Unit and Display Unit, but radio waves are not being transmitted.

Approximately 90 seconds after switching to STBY, the READY light will glow, meaning the radar is available for operation.

In ON position, (with the **READY** light glowing) the system is transmitting, and any echoes from targets received are amplified and displayed on your screen.

2) **RANGE**

The seven **RANGE** switches select the scale which you wish the radar to display. The range selected automatically determines the proper number and calibrated distance between the range rings and the proper transmission pulse length as shown in Table 2-1.

TABLE 2-1 RELATION OF RANGE, RINGS AND PULSE LENGTH

Range (nm)	Range Rings Interval (nm)	Number of Rings	Pulse Length (μs)
0.25	0.125	2	0.12
0.5	0.25	2	0.12
1 1	0.25	4	0.12
2	0.5	4	0.12
4	1	4	0.5
8	2	4	0.5
12	3	4	0.5

3) **TUNE**

The **TUNE** control allows you to maximize target echoes by “fine” tuning of the local oscillator which is located in the Scanner Unit.

4) **GAIN**

The **GAIN** control varies the amplification in the receiver, and thus the strength of echoes as they will appear on the screen.

5) **SEA CLUTTER**

The **SEA CLUTTER** control reduces the gain level at short range only.

6) **RAIN CLUTTER**

The primary use of **RAIN CLUTTER** is to break up the returns from rain or snow thus allowing weaker targets to become visible.

7) **SHM MARKERS (SHM, MARKERS – SHM – MARKERS – OFF)**

The **SHM MARKERS** switch is a four position switch which selects the **SHM**, markers, both or none for the display.

8) **CRT BRIL**

The **CRT BRILLIANCE** controls 4 levels of the screen brightness.

9) **IR**

The **IR** switch turns the interference rejecter “on” to eliminate interference from other ship radars.

10) **HOLD**

The **HOLD** switch is used to temporarily “freeze” the picture on the screen to assist the operator in determining bearing and ranges. Pushing the **HOLD** switch stops the transmission of **RF** power releasing the switch restores normal operation.

2.1.3 Operating Procedure

– TO SWITCH ON –

To switch on the radar, proceed as follows:

- 1) Set the **OPERATE** switch to **STBY**.
- 2) After **READY** light glows (approximately 90 seconds), set the **OPERATE** switch to **ON**.
- 3) Set the **CRT BRILLIANCE** switch so as to obtain desired brightness of the screen.
- 4) Set range scale to the 4, 8 or 12 mile range.
- 5) Assure that **RAIN CLUTTER**, the **IR** switch, and **SEA CLUTTER** are **OFF**.
- 6) Adjust **GAIN** control to produce a light background speckle screen.
- 7) Adjust **TUNING** control for maximum echoes on the screen. If there is no target available (that is, in the open sea) adjust **TUNING** for the maximum strength of sea clutter.
- 8) Push **RANGE** switch of the scale you wish to cover.
- 9) **RAIN CLUTTER** if necessary, **STC** as necessary.
- 10) If necessary, press **IR** to reduce radar interference. When the radar is no longer required, set the **OPERATE** switch to **OFF**. If you want to keep the radar in a state of immediate readiness, the **OPERATE** switch should be set to **STBY** position.

2.2 RANGE AND BEARING MEASUREMENTS (See Figure 2-2)

The picture on the screen shows a plan view of the position of targets around your vessel. In effect your ship is at the center of the screen and targets are presented in polar coordinates (or map-like) throughout 360 degrees. The display is referred to as the PPI (Plan Position Indicator).

2.2.1 Range Measurement

To measure a target's range proceed as follows:

- 1) Note the range scale in use and the distance between rings.
- 2) Count the number of rings between the center of the screen and the target, and visually estimate the distance between the inner edge of the target and inner edge of the nearest ring.

2.2.2 Bearing Measurement

Using bearing scale engraved on the screen filter, read the bearing where the radial line passes through the center of the target. The reading you obtain will show the targets relative bearing in degrees.

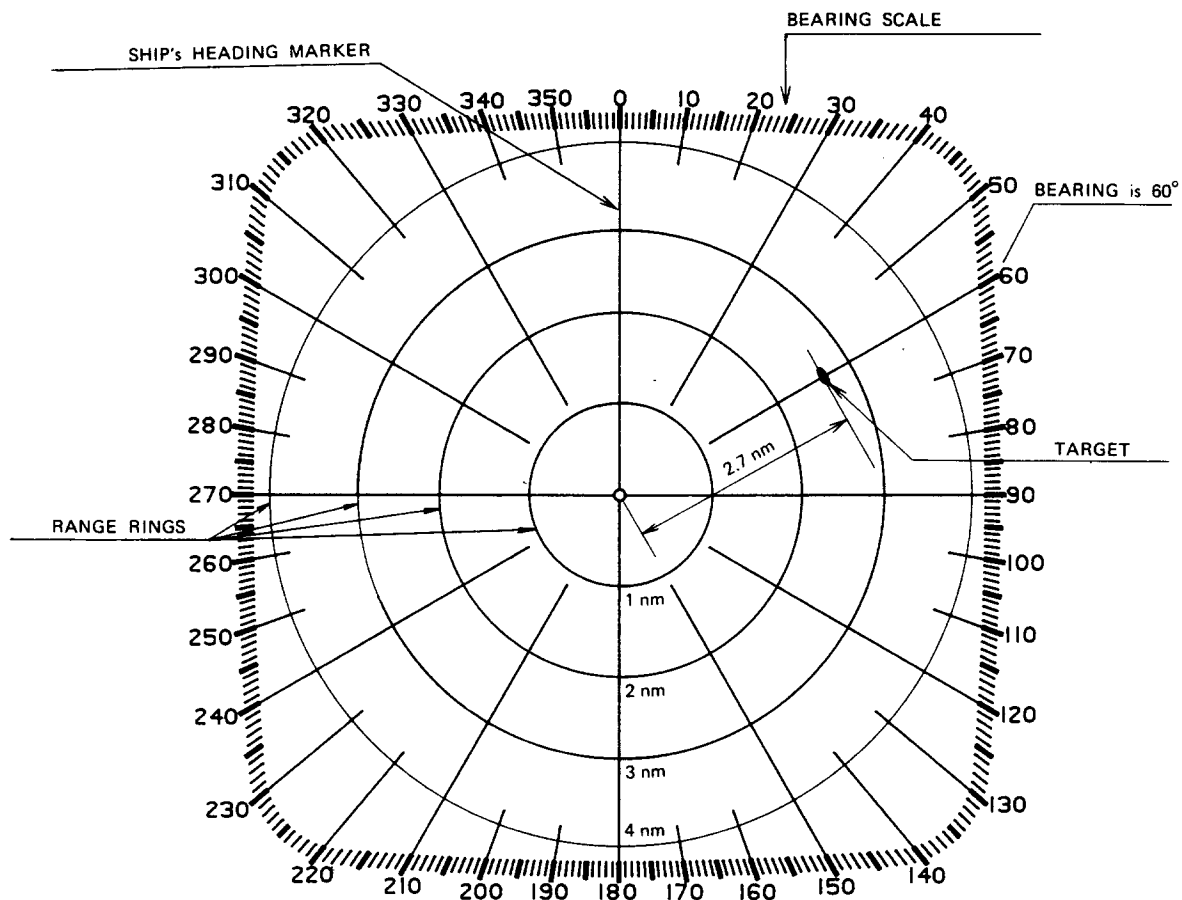

FIG. 2-2 RANGE AND BEARING MEASUREMENTS

2.3 USING THE CONTROLS

2.3.1 TUNE Control

The magnetron and the Gunn oscillator may take about 10 minutes to completely stabilize on frequency. So after switching on and tuning initially, the tuning should be rechecked after the first 10 minutes.

Symptoms that the equipment may be out of tune are a lack of distant echoes or the appearance of double echoes (one echo behind another). The coarse method of tuning is described in Section 5. Normally it is possible to fine tune the radar by selecting a comparatively weak echo and then rotating the **TUNE** control until the strongest echo and best definition are combined.

2.3.2 GAIN Control

The correct setting of the **GAIN** control is for light background speckle to be just visible on the screen. The equipment is then in its most sensitive condition. Objects will be detected at the greatest possible range. With too little gain, weak targets may be missed and there can be a decrease in detection range. With excessive gain (a few) extra targets may be brought in, but the contrast between echoes and background noise will be substantially reduced, making target observation more difficult.

In crowded regions gain might be temporarily reduced to clarify the picture. This must be done with care since important marks may be missed. With gain at its normal setting, clutter from rain or snow may obscure the echo from a ship inside a squall or storm. A temporary reduction in gain will usually permit the stronger and more distinct ship's echo to be distinguished.

Detection of targets beyond the storm may, however, require slightly higher gain than normal, since the clutter may have attenuated, but not completely obscured, echoes from the targets. The **GAIN** control should be always returned to its normal position as soon as any temporary alteration is no longer required.

2.3.3 SEA CLUTTER Control

Whereas the **GAIN** control affects the strength of echoes at all ranges, the effect of **SEA CLUTTER** control is greatest on short-range echoes, becoming progressively less as range increases. The **SEA CLUTTER** control is only effective up to a maximum of about three miles.

In particular, the **SEA CLUTTER** control reduces the strength of the mass of random signals received from waves at short range. The setting used should be sufficient to reduce the strength of signals until clutter appears only as small dots, and until small targets can be distinguished, the setting should never be advanced so far as to blank out all clutter.

The sensitivity of the **SEA CLUTTER** control is fully variable, thus enabling an optimum picture to be obtained under adverse weather conditions.

Maximum reduction in the strength of close-range echoes takes place when the control is turned fully clockwise. When it is turned counterclockwise there is no reduction in the strength of echoes.

The **SEA CLUTTER** control may be used to reduce some rain or snow clutter, as well as strong sea clutter, in the immediate vicinity of the vessel. A temporary increase in the setting will usually permit strong echoes from ships, and most navigational marks inside storms or squalls, to be distinguished.

At close range in crowded regions the control may be temporarily advanced to clear the picture. This should be done with care, so as to avoid missing important echoes.

The **SEA CLUTTER** control should be always returned to its optimum position after any temporary alteration.

2.3.4 RAIN CLUTTER Switch

During heavy rain or snow which may clutter the picture, use **RAIN CLUTTER** to give better contrast between echoes and the clutter. Under some conditions of sea return, both **RAIN CLUTTER** and **SEA CLUTTER** will help to clarify the picture. When viewing large masses of land, coastlines, etc. **RAIN CLUTTER** reduces the background and will cause promontories to stand out more clearly.

2.3.5 IR Switch

When another ship radar is using the same frequency band as that of your own interference typically appears arranged in curved spokes as shown in Figure 2-3. The radar interference is mainly noticeable on longer range scales.

Using the **IR** switch will eliminate this form of interference as well as any other form of a synchronous noise.

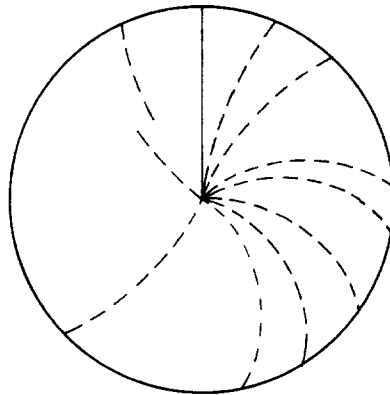

FIG. 2-3 RADAR INTERFERENCE

2.4 NAVIGATION WITH THE RADAR

2.4.1 Obtaining a Position Fix

The Model 1200 Radar is an accurate and reliable navigational aid for determining your ship's position. Figure 2-4 shows examples of alternative methods of using radar sightings from prominent navigational points which can be identified on a chart. A position fix based on two or more navigational points will furnish a more accurate fix, especially when the points approach 90 degrees apart from your ship's position.

2.4.2 Avoiding Collision

The moment a target appears on the screen, its range and relative bearing should be noted. This is best done on a plotting sheet or chart.

As in visual observation, "a constant bearing indicates a collision course".

As soon as a series of plots indicates a closing range and no significant change in successive bearings, positive action should be considered mandatory and "The Regulations for Preventing Collisions at Sea" should be observed.

2.4.3 Determining Your Radar Line-of-Sight Range

When searching for distant targets, your radar line-of-sight range to the target can be a limiting factor. Radar waves behave like light waves but they are refracted slightly more, increasing the distance to the radar horizon slightly more than that to the optical horizon (however, displayed range is correct). As Figure 2-5 shows, the radar line-of-sight range is a combination of the radar horizon of your ship's radar scanner and the radar horizon of the target.

The distance to the radar horizon from radar scanner of height "h" meters, under standard conditions, may be calculated from the formula

$$\text{Distance (nm)} = 2.23 \sqrt{h}$$

For example, a scanner at a height of 5 meters has a radar horizon of 5 nm.

A 5 meters cliff has a radar horizon of 5 nm. Therefore, under standard conditions, the cliff should begin to appear on the screen when ship closes nearer than $5 + 5 = 10$ nm.

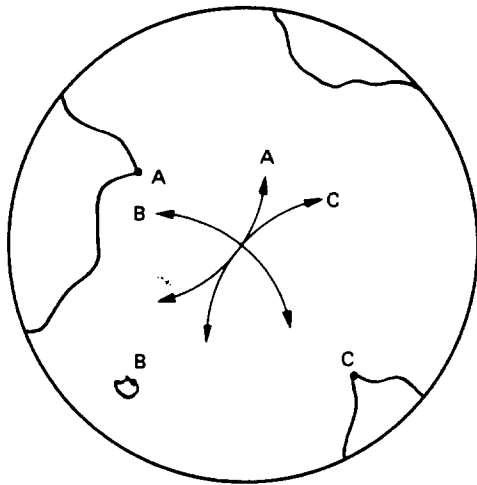

A. THREE RANGE ARCS PLOTTED ON CHART

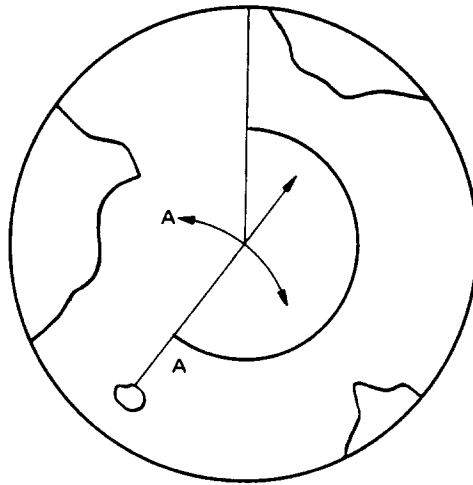

B. ONE RANGE ARC AND ONE BEARING PLOTTED ON CHART

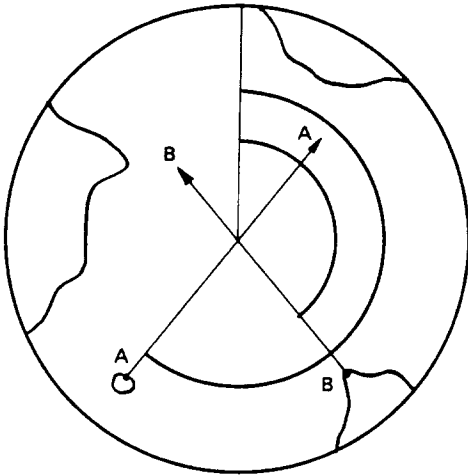

C. TWO BEARINGS PLOTTED ON CHART

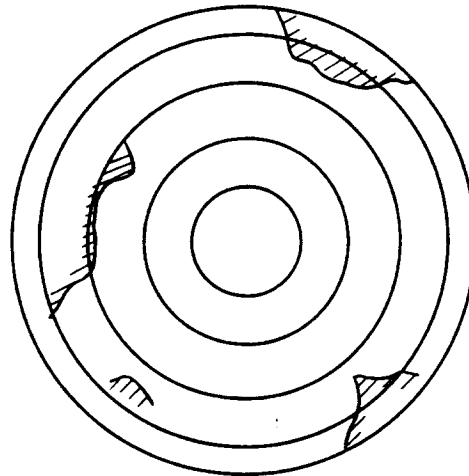

D. RADAR SCREEN POSITION

FIG. 2.4 POSITION FIX METHODS

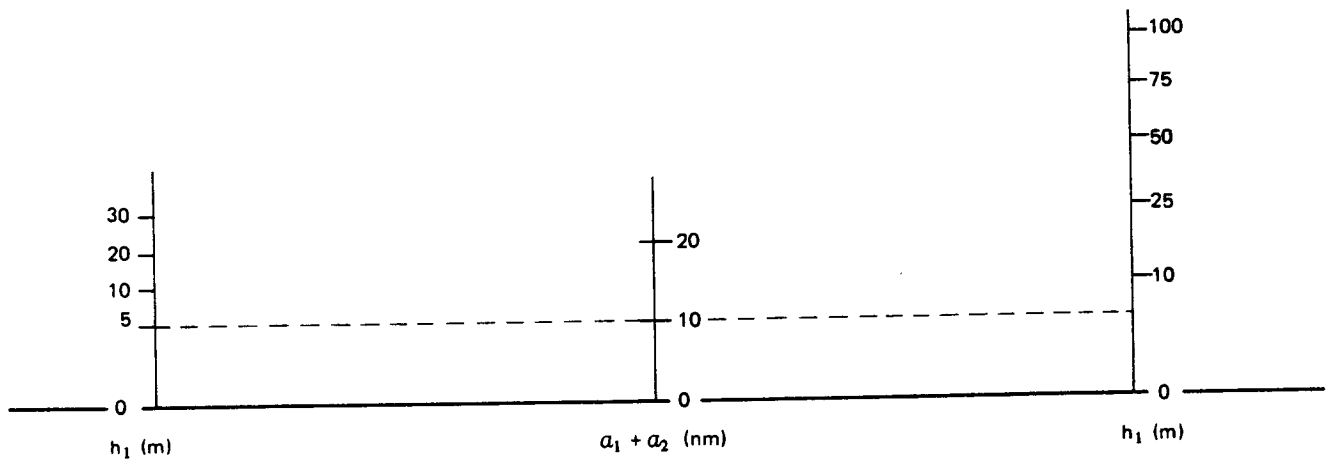
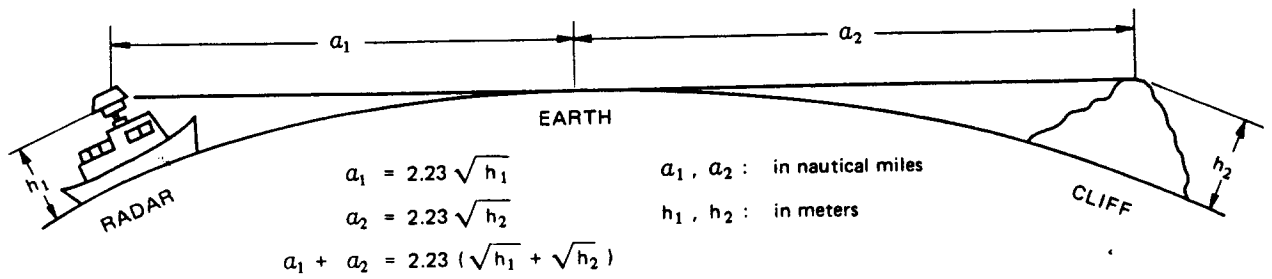

FIG. 2-5 RADAR HORIZON

2.5 FALSE ECHOES

Occasionally, signals appear on the screen at positions where there is no target. They are false echoes.

The following are known as most common false echoes.

2.5.1 Side Echoes

Some radiation escapes on each side of the main beam in side lobes. If they are reflected by a target, they will be displayed on the screen as an echo. (See Figure 2-6)

These echoes appear as arcs from echoes at each side of the true echo. Sometimes joined together if the side echoes are strong.

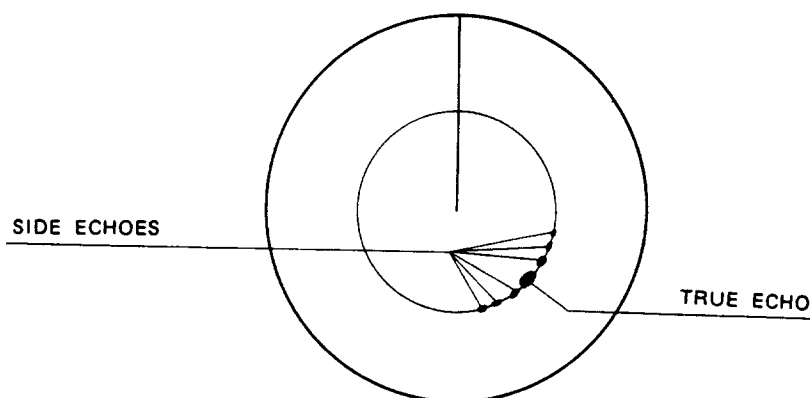

FIG. 2-6 SIDE ECHOES

2.5.2 Indirect Echoes

As shown in Figure 2-7, indirect echoes may appear if there is a large target, such as a passing ship, at a short range or a reflecting surface, such as a funnel, on your own ship. The signal, on first striking the smooth side of the large target, will be deflected. Then it encounters a second target, the echo will return along the same paths to the scanner. Thus, the echo from the second target will appear beyond that of the large target but on the same bearing. The indirect echoes will also appear when the signal will be deflected by the reflecting surface.

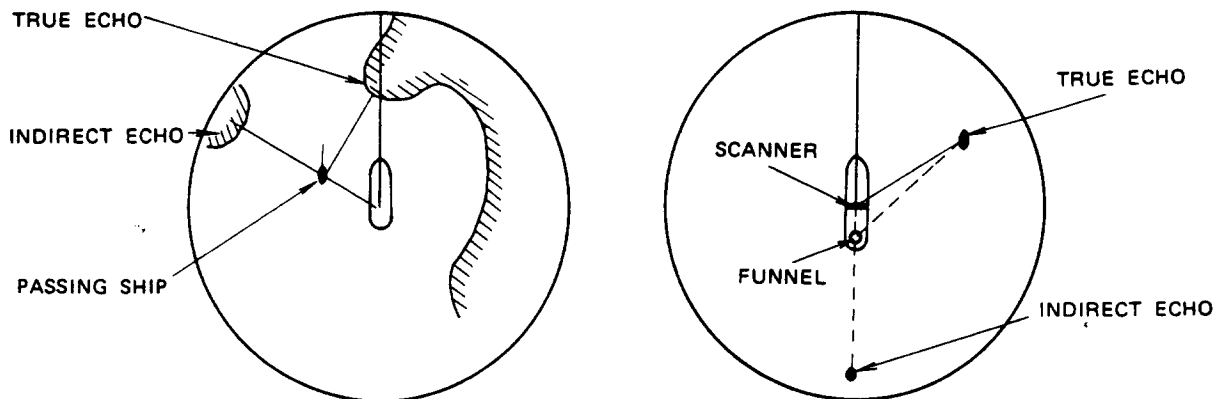

FIG. 2-7 INDIRECT ECHOES

2.5.3 Multiple Echoes

The multiple echoes may appear if there is a large target having a wide vertical surface parallel to your own ship at comparatively short ranges. The signal will be reflected by the wide vertical surface, then the reflected signal strikes your own ship, and it will return along the same path to the target. This will be repeated. Thus, the multiple echoes will appear beyond the true target's echo on the same bearing as shown in Figure 2-8.

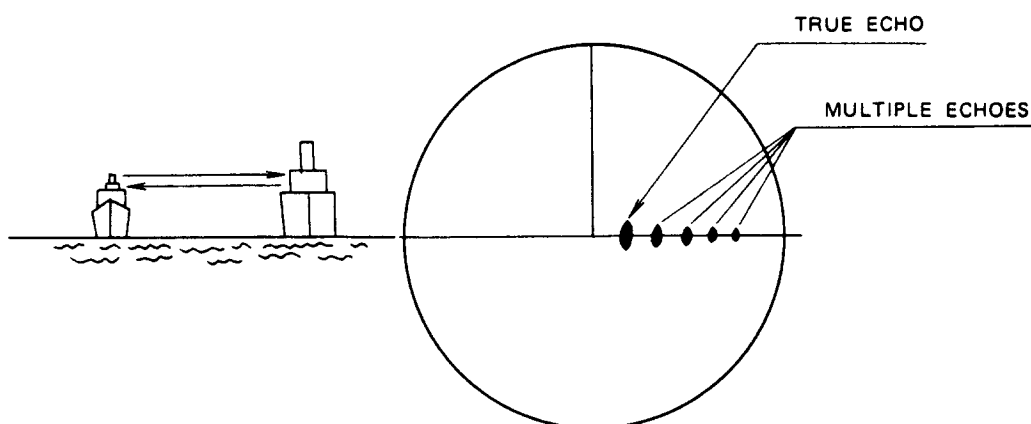

FIG. 2-8 MULTIPLE ECHOES

2.5.4 Ghost Echoes

The ghost echoes may appear if there is a target having a wide smooth surface near your own ship. As shown in Figure 2-9, the appearance of the ghost echoes is similar to that of the indirect echoes.

The ghost echoes appear on the screen as if you saw the target reflected in a mirror.

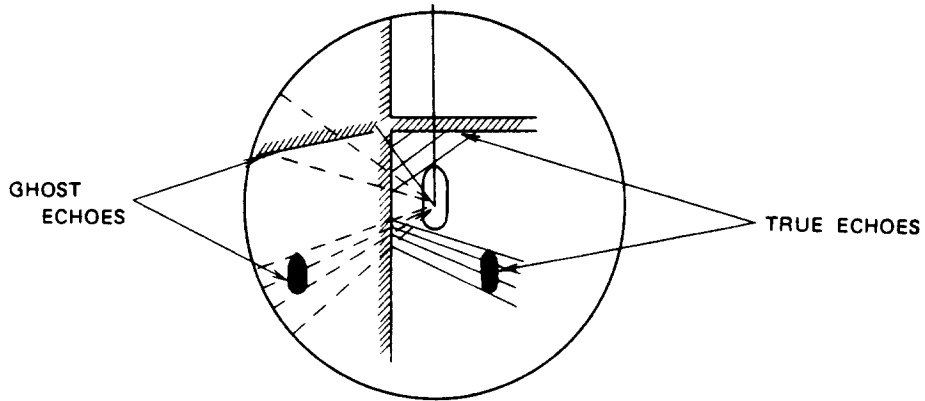

FIG. 2-9 GHOST ECHOES

2.5.5 Shadows

Although the scanner unit should be ideally placed where there is a good all-around view, as far away as possible from any part of the ship's superstructure or rigging to reflect the beam, there may be some obstructions. An obstruction will throw either a complete or partial shadow as shown in Figure 2-10.

If there are targets in such shadow sector, target's echoes may not be displayed on the screen. Thus, it is important to know the bearings and width of all shadow sectors, and it can be checked by turning the **SEA CLUTTER** control to zero when light rain clutter covers much of the screen and the sea is calm.

Any shadow will then be shown dark sectors in the clutter.

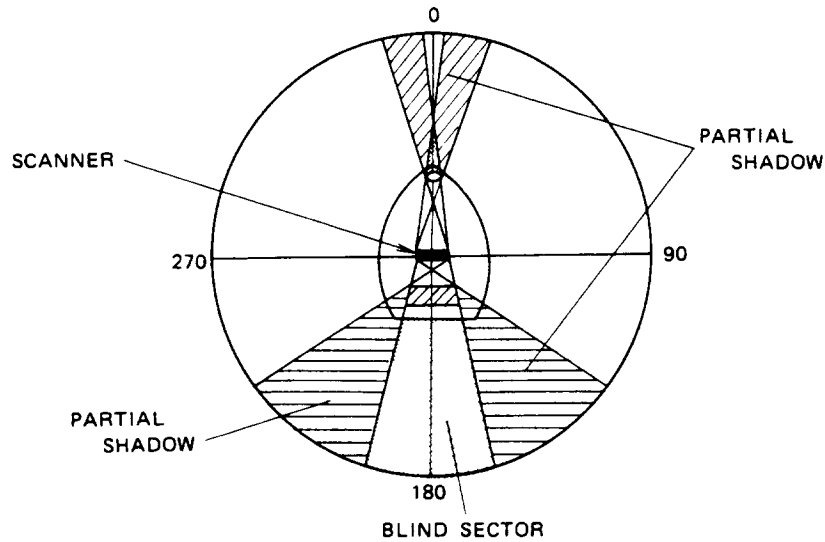

FIG. 2-10 SHADOWS

SECTION 3

MAINTENANCE

3.1 GENERAL

Continuing satisfactory operation of the radar can depend on how well you care for your equipment. The simple maintenance tips that follow can save you time, and money and help avoid premature equipment failure.

CAUTION

When working on the radar, make sure that the main switch which supplies power to the radar is open. As an additional precaution, keep the **OPERATE** switch on the Display Unit in the OFF position.

- 1) Keep the equipment as clean as possible. Use a soft cloth to remove dirt, dust, water-spray as it appears.
- 2) Periodic inspection of the radar systems should include the following:
 - a. Check all hardware for tightness.
 - b. Check for evidence of any corrosion of the scanner, display or cables and clean as required.
 - c. Check cables and terminal connections for cleanliness, tightness, and freedom from chafing or abrasions.

3.2 SCANNER UNIT

Set the safety switch (S101) of the Scanner Unit to OFF before working on the radar.

3.2.1 Radome

Wipe the surface of the Radome with a clean, soft cloth. Check that there is no paint, dirt or caked salt. A heavy deposit of dirt or caked salt on a painted surface of upper Radome will cause a considerable drop in the radar performance. Don't use any chemical cleaners except alcohol.

3.2.2 Lubrication

Locate main drive gear, clean away old lubrication residue and dirt. Using a spatula, apply a light coating of grease (MOBILUX Grease No. 2 Mobil Oil Company or equivalent) on the gear of the main shaft and the drive motor. Lubrication should be done every six months.

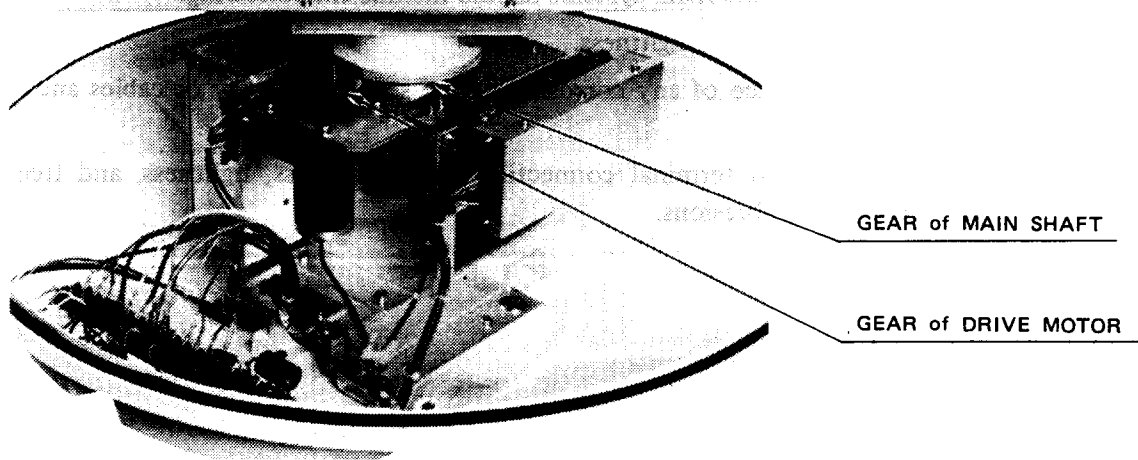

3.2.3 Mounting

Check the mounting bolts of the Scanner Unit and tighten if necessary.

3.3 DISPLAY UNIT

3.3.1 Cleaning the Screen

The face of screen filter and cathode-ray tube will, in time, accumulate a film of contaminants which tends to dim the picture.

Be sure **OPERATE** switch is OFF. Remove the front panel. Removing Front Panel Procedure: Remove 4 screws retaining top and bottom covers. Remove 4 screws securing front panel to display. Lay Front Panel forward gently for clearing of CRT face.

3.3.2 High Voltage Circuit

Clean the printed CRT display circuit board components and CRT anode with a dry, soft cloth or a clean, soft brush. A coating of dust can cause voltage breakdown in the circuit and malfunction of the radar.

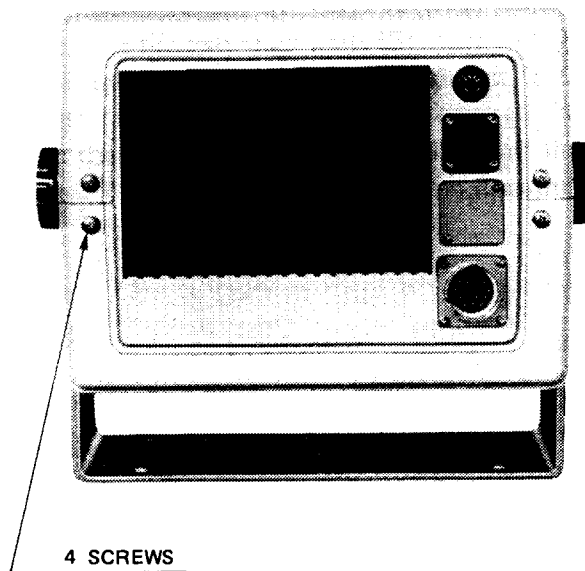

REMOVE 4 SCREWS
RETAINING TOP
AND BOTTOM COVER

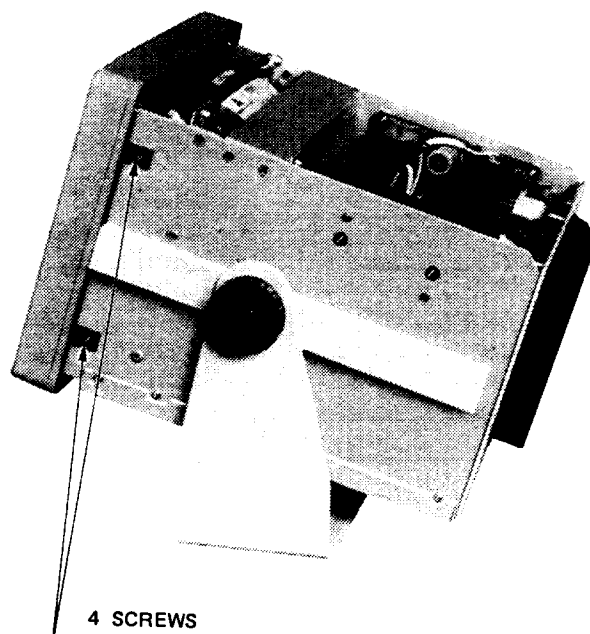

REMOVE 4 SCREWS
SECURING THE
FRONT PANEL

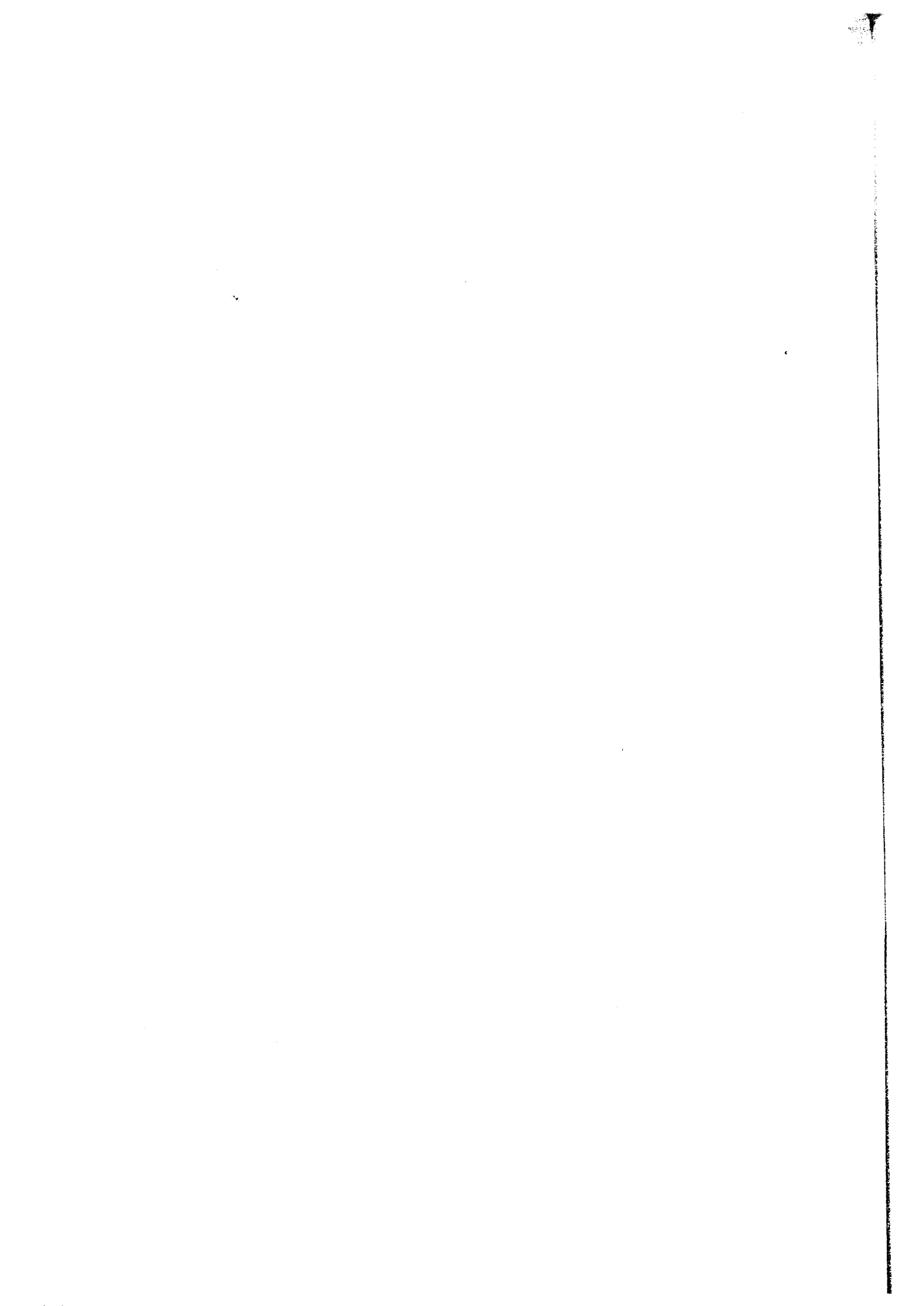

SECTION 4

INSTALLATION

4.1 PLANNING

The layout for installing the 1200 Radar should be planned to give the best operation and service aboard your particular ship. In general, the Scanner Unit should be mounted atop the wheelhouse or bridge as high as possible. The Display Unit should be installed in the wheelhouse at a convenient viewing position.

A 10 meter length of Vinyl-covered, shielded, 11 conductor cable is furnished for interconnecting the two main units (Scanner and Display).

This length of cable should be sufficient to fabricate the cable runs required on most small ships: additional cable may be ordered from RAYTHEON. The maximum length cable from the Scanner Unit to the Display Unit should not exceed 20 meters.

Figure 101 shows the General System drawing for the 1200 Radar.

4.2 INSTALLATION OF SCANNER UNIT

4.2.1 Selecting the Location

Selecting an adequate location for the Scanner Unit requires careful consideration. On many small ships, the unit can be installed directly on the top deck of the wheelhouse near the ship's centerline. The unit should be mounted as high as possible on the ship to ensure best performance at the maximum range. (Refer to para 2.4.3)

The scanning beam should not be obstructed by nearby large objects. Locate the unit where large structures such as superstructures or searchlights, or horns, masts are not in the same horizontal plane, otherwise, blind areas and false targets can appear on the radar screen. Installation near the top of a stack must be avoided as damage could result due to excessive heat and the corrosive effects of stack gases.

4.2.2 Mounting the Scanner Unit

Using the outline drawing of Figure 102 as a guide, install the Scanner Unit and secure to the mounting surface. The mounting surface for the Scanner Unit should be parallel with the ship's waterline, and the unit must be turned with the cable inlet astern (safety switch aft).

If mounting directly to a top deck does not give sufficient height or clearance, a radar mast or pedestal may be used to raise the unit.

4.2.3 Connecting the Cable

The cable entrance is provided in the base of the Scanner Unit.

If the unit is mounted on a hollow mast, the cable may be run inside the mast and through the center entrance hole.

Connect the cable leads onto terminal board TB101 as shown in below.

Terminal lugs are provided in the Scanner Unit.

Fig. 4-1 details the connecting procedure for the Scanner Unit.

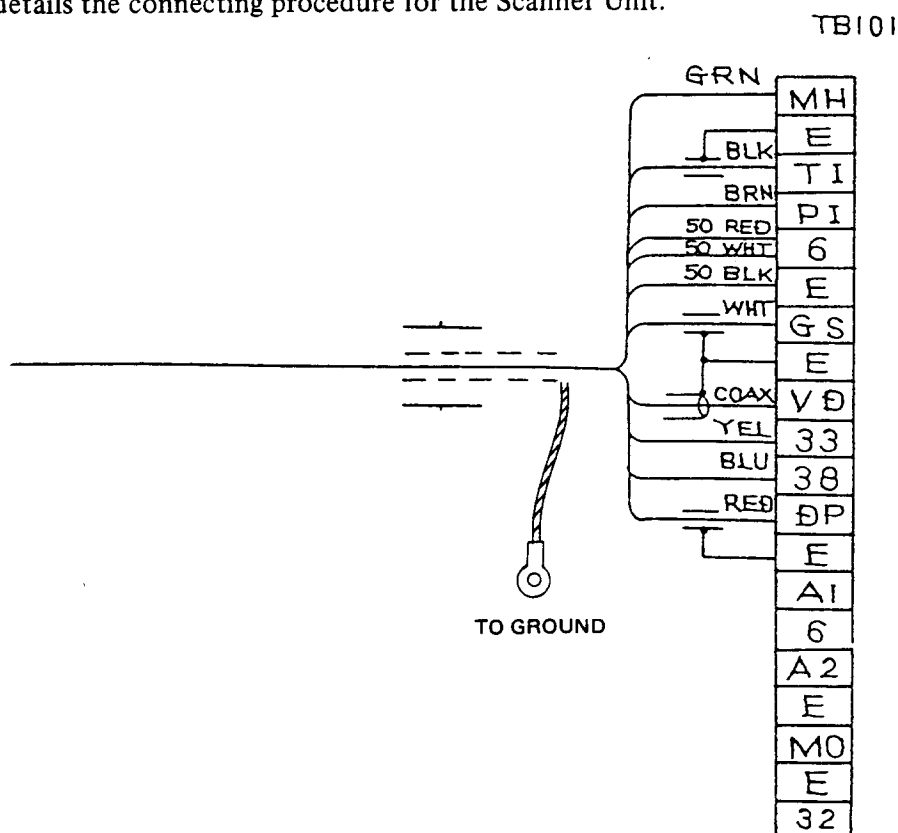

1.

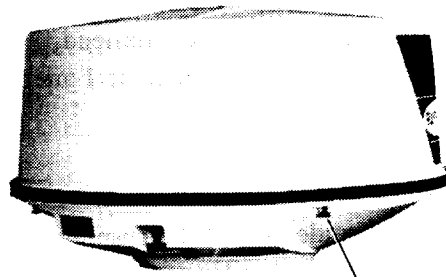

**LOOSEN FOUR CLAMPING
BOLTS**

CLAMPING BOLTS (4)

2.

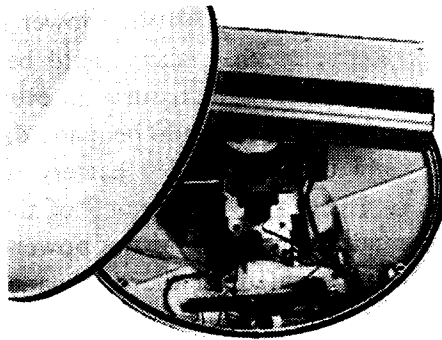

**REMOVE THE RADOME
FROM THE BASE
and
INSERT THE CONNECTING
CABLE IN THE CABLE
INLET.
ADD THE RUBBER GROMMET,
and SECURE THE CLAMPING
PLATE.**

3.

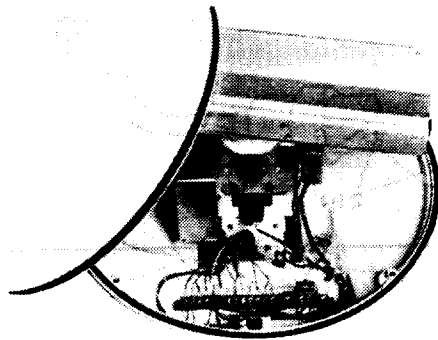

**CONNECT THE CABLE
LEADS WITH TERMINAL
BOARDS TB101.
GROUND THE SHIELD
WITH THE LUG
PROVIDED.**

Fig. 4-1 CONNECTING PROCEDURE FOR SCANNER UNIT

4.3 INSTALLATION OF DISPLAY UNIT

4.3.1 Selecting the Location

Ideally, the Display Unit should be located in the wheelhouse so the radar screen can be viewed when looking forward from the wheel. The Display Unit can be mounted on top of the chart table hung from the overhead, or installed against the bulkhead.

To minimize interference the location chosen should be at least 1 meter away from the ships compass and Loran C receiver.

4.3.2 Mounting the Display Unit

Using the outline drawing of Figure 103 as a guide, install the Display Unit and secure to the mounting surface. Note that the yoke of the Display Unit can be attached above or below the unit.

4.3.3 DC Power Connector

A three pin connector is furnished for connecting the 13.6 Vdc power to the radar. The power cable from the 13.6 volt power source to the radar should be number 14 stranded wire for a run of less than 10 feet. Longer cable runs require an even larger wire size to minimize the voltage drop (Table 4-1). Connections should be made directly to the battery. Check that all connections are clean and bright. The (+) battery wire must be connected to pin 1 of the connector and the (-) battery wire to pin 3 of the connector. Pin 2 should be connected to the ships RF ground system. Should the power connections be inadvertently reversed, protective fuse F1 (7A), located on the rear panel, will blow. Recheck the input power leads for correct polarity with a VOM, reconnect the leads observing correct polarity and replace the fuse.

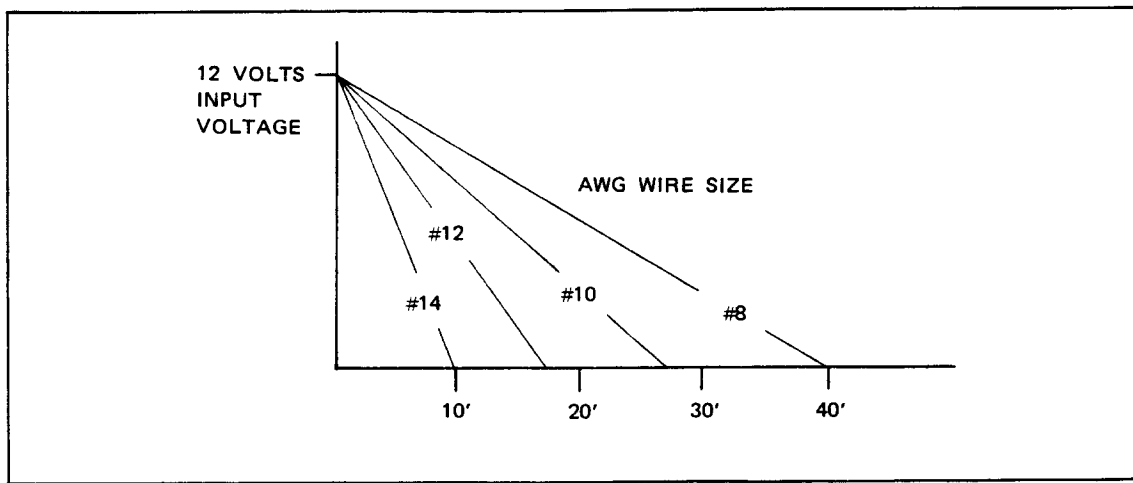
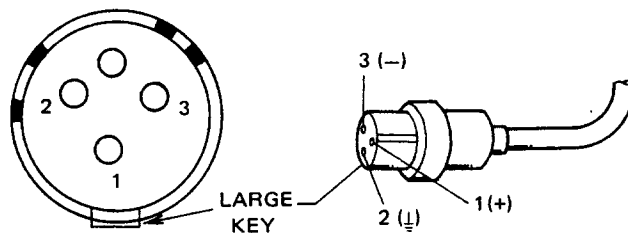

POWER CABLE LENGTH

TABLE 4-1 POWER CABLE SIZE VERSUS LENGTH

Note: If a longer cable run for power is required, it may be more convenient to bring a power distribution point to the proximity of the radar display using proper sized cable in order to use manageable conductor sizes at the plug.

4.3.4 Connecting the Cables

Connect the cables to the J501 and J502.

FIG. 4-2 details the connecting procedure for the Display Unit.

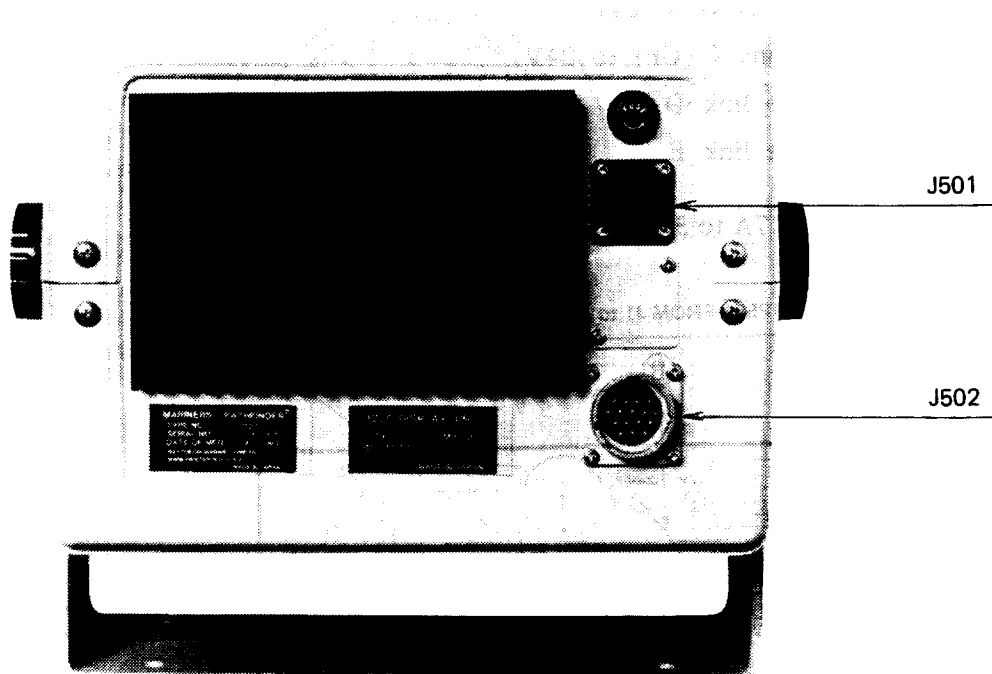

FIG. 4-2 DISPLAY REAR PANEL

4.4 CHANGE OF SHIP'S MAINS INPUT TO 24 OR 32 V

4.4.1 Scanner Unit

No change.

4.4.2 Display Unit

- 1) Display Unit factory wired for 12 V dc.

To change the ship's mains input from 12 V dc to 24, 32 V dc, make the link changes as follows.

- A. Change plug P501 to J2
- B. Move link B to 24V
- C. Move link C (UP) to 24V
- D. Remove link D
- E. Remove link E

- 2) Change fuse from 7A to 3A.

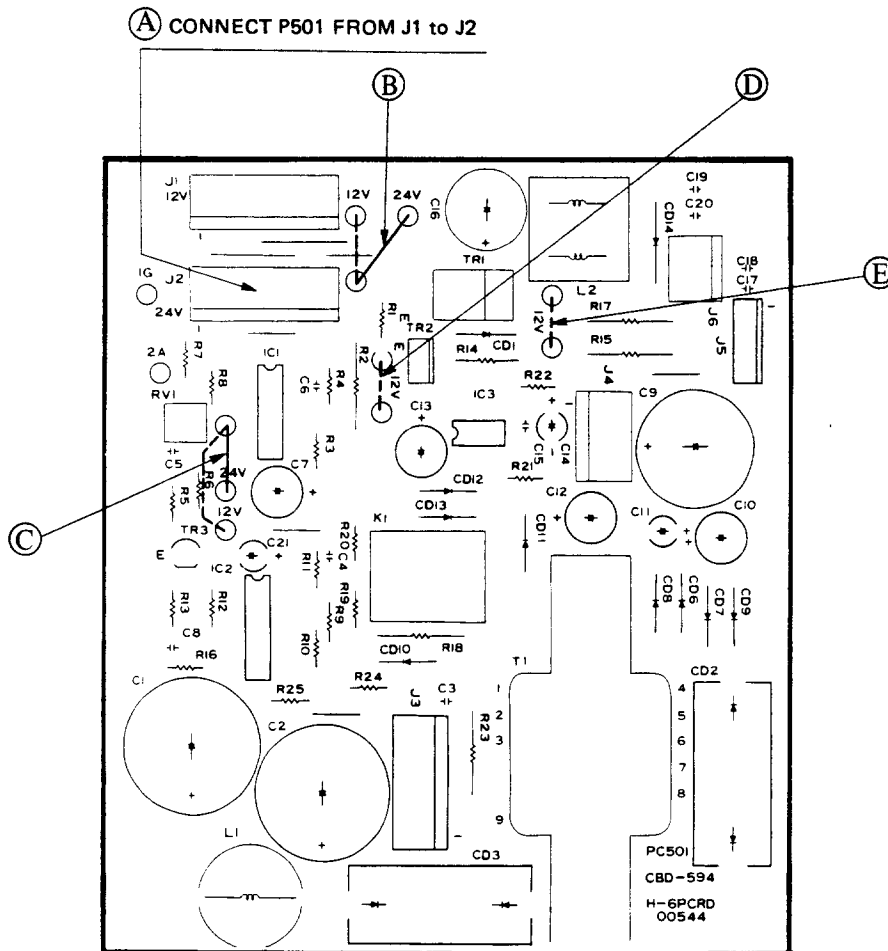
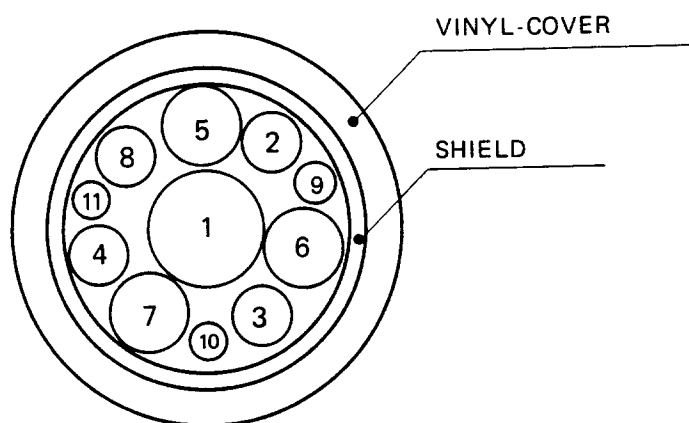

FIG. 4-3 CHANGE ARRANGEMENT FOR SHIP'S MAINS INPUT

4.5 CABLE INFORMATION

4.5.1 Composite Cable Type H-2695110006

This cable is vinyl-covered, shielded, 11 conductor cable connecting the Scanner Unit with the Display Unit. Specification of this cable is as follows:



Conductor (No.)	Cross Section (mm ²)	Conductor Type	Color	Remarks
1	0.5	19/0.18		Coaxial
2	0.3	12/0.18	Black	Shielded
3	0.3	12/0.18	White	"
4	0.3	12/0.18	Red	"
5	1.25	50/0.18	Black	250 V
6	1.25	50/0.18	White	250 V
7	1.25	50/0.18	Red	250 V
8	0.3	12/0.18	Green	600 V
9	0.3	12/0.18	Yellow	250 V
10	0.3	12/0.18	Brown	250 V
11	0.3	12/0.18	Blue	250 V

TABLE 4-2 SPECIFICATION OF COMPOSITE CABLE TYPE H-2695110006

4.6 INITIAL OPERATION AND CHECKOUT

4.6.1 Inspection After the Installation

After completing the installation, it is necessary to assure that all the steps of the installation were accomplished in accordance with the instructions.

In particular, inspect to insure that the cables are not crimped or damaged and an input voltage connected accurately; voltage linking is correct; the securing bolts of each equipment are tightened; a water leak has not occurred in the Scanner Unit, and that the connection of the cable shield is made properly to RF ground.

4.6.2 Operational Check

Apply power to radar and switch to standby (STBY). In approximately 90 seconds the READY light should glow.

Switch radar to ON and observe presence of a sweep line which originates from the center of the CRT and extends to the edge. Switch on the range markers and while pushing the range selector through each range scale, observe that the sweep is the correct length and has the proper number of range rings. Observe that the range markers are focused properly.

Rotate GAIN control and observe the presence of targets and noise. Rotate SEA CLUTTER control on 1/2 mile scale and note the reduction of close in gain and targets.

After approximately 10 minutes of operation, rotate the TUNE control and observe that maximum target returns occur at the center of the TUNE range.

If readjustment of the display or T/R is required, refer to paragraph 5.1.1 and 5.1.2.

4.6.3 Relative Bearing Alignment

This alignment must be carried out by the engineer when installation is complete. When the ship is underway, proceed as follows:

- (1) Identify a suitable target (e.g., ship or buoy etc.) preferably between 1.5 and 3 nm in range on the screen.

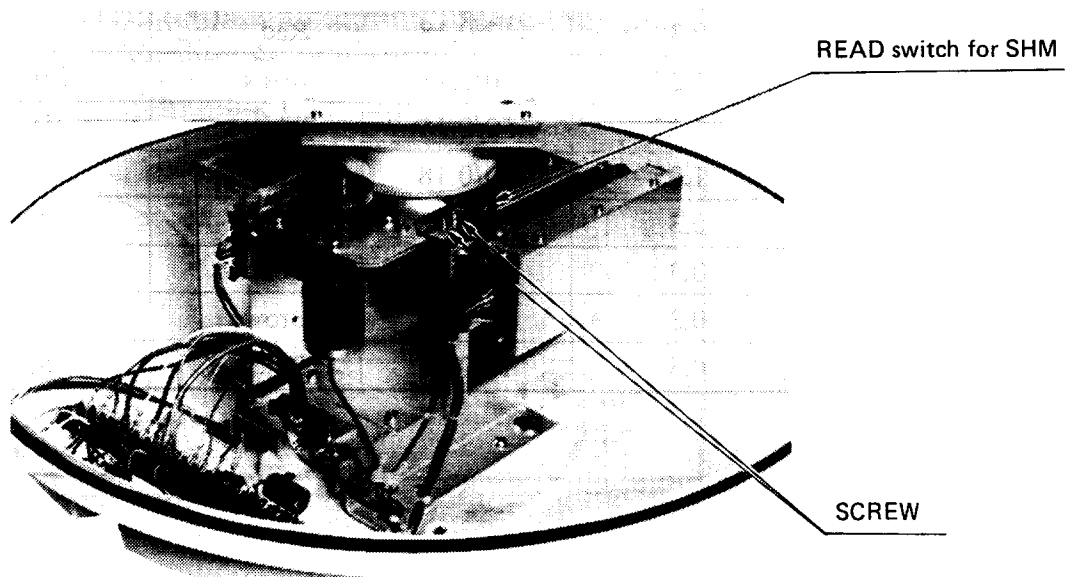
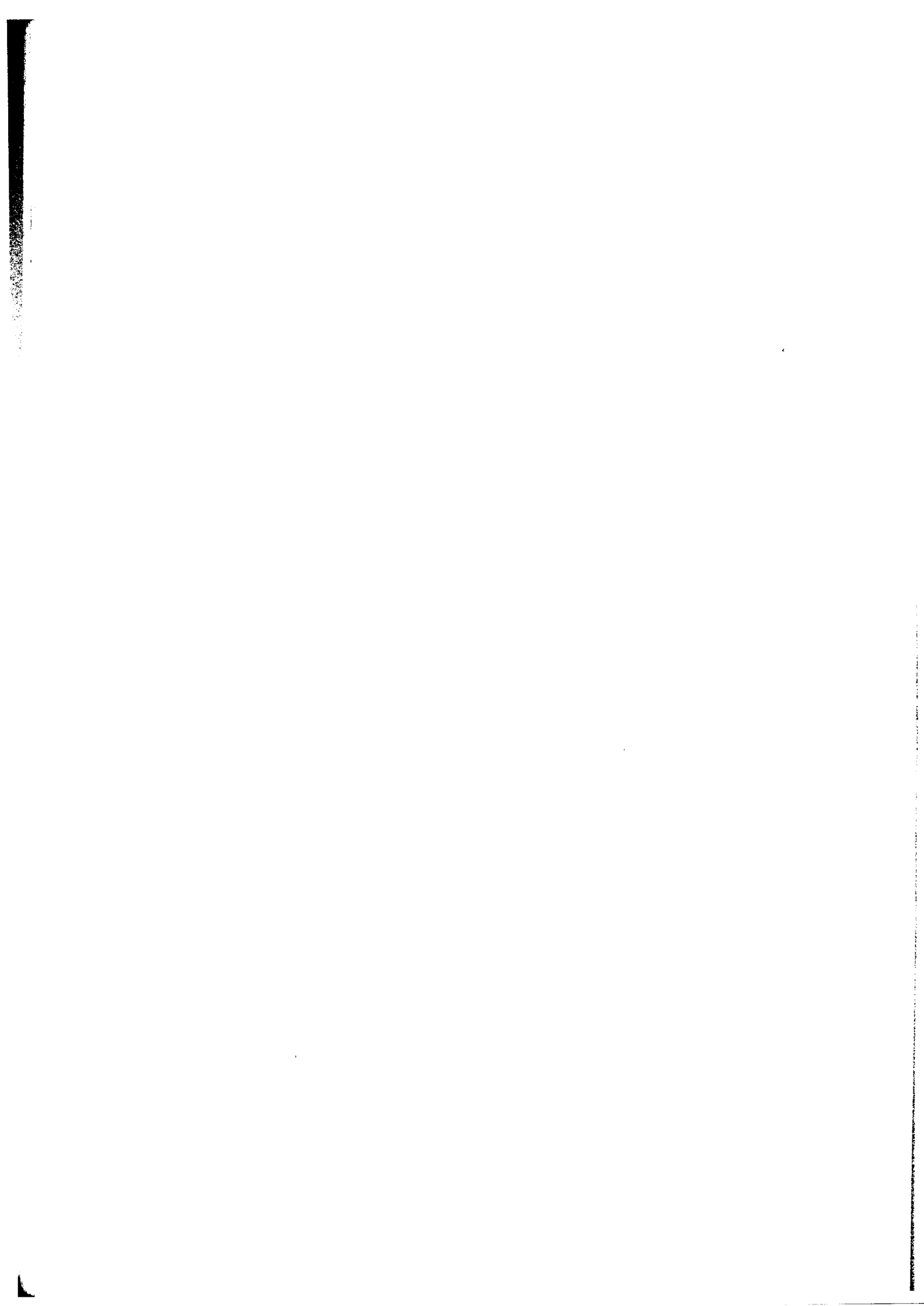

Fig. 4-5 RELATIVE BEARING ALIGNMENT

- (2) Head the vessel to the target.
- (3) Establish the bearing of the target on the screen.
- (4) Compare the bearing measured in step (2) and (3) above and calculate the direction and magnitude of the bearing error.
- (5) Loosen the screws which secures the SHM unit in the Scanner (*See Figure 4-5*).
- (6) Rotate SHM unit clockwise or counterclockwise until the bearing of the target on the screen is the same as the bearing of step (2).
- (7) Tighten the screws, checking that the scale reading does not alter.

5.1.2 0 nm (Zero nm) ADJUSTMENT (*See Fig. 5-3*)

Set the **RANGE** at 0.25 nm and observe a target at a known real (nearest) distance. Adjust RV3 so that the target real distance will be coincident with the displayed distance on the screen.



SECTION 5

ADJUSTMENT AND FAULT FINDING

5.1 ADJUSTMENT

5.1.1 Adjustment for Replacing Components

Although the radar is delivered adjusted for optimum performance, it may be necessary to make adjustments after a major component has been replaced or if a fault is suspected during operation.

NOTE

REPLACEMENT ITEM	ADJUSTMENT REQUIRED	See Sect. #
Magnetron V201	Gunn Oscillator tuning	(1)
Gunn Oscillator A301	Gunn Oscillator tuning	(1)
Cathode-ray tube V401	Adjusting centering magnet	(2)
Display PCB	Adjusting intensity	(3)
	Adjusting focus	(4)
SHM Unit S102	Bearing Alignment (See para. 4.6.3)	

1) Gunn Oscillator tuning (See Fig. 5-1)

Method A – For two men working at the scanner position and the other at the display position. They can communicate with one another directly or by telephone, etc.

- a. About 10 minutes after operating the radar, set **RANGE** between 0.5 and 3 nm.
- b. Rotate the **TUNE** control of the Display Unit to midposition.
- c. Set the **SAFETY** switch S101 of the Scanner Unit to OFF.
- d. Remove the Radome from the pedestal of the Scanner Unit.
- e. Turn antenna array manually until it encounters some solid land echoes.
- f. Set the **GAIN** control so that noise on the sweep trace is discernible.
- g. Adjust the mechanical tuning knob of the Gunn Oscillator (A301) so as to maximise the echoes on the screen.

Method B – For one man at the scanner position only.

- a. Carry out instructions for steps a. through f. of method A, except that the **RANGE** selector setting can be at any range between 8 and 12 nm.
- b. Connect the Circuit Tester on 5 to 10 volt dc range to TB101-32 with the negative lead to chassis.
- c. Adjust Gunn Oscillator mechanical tuning for a peak reading on the meter.

Note: The Circuit Tester for tuning above mentioned is required its internal resistance more than $10k\Omega/V$.

There may be more than one peak reading. The proper peak is the first peak observed when turning the ADJ Screw CW from full CW.

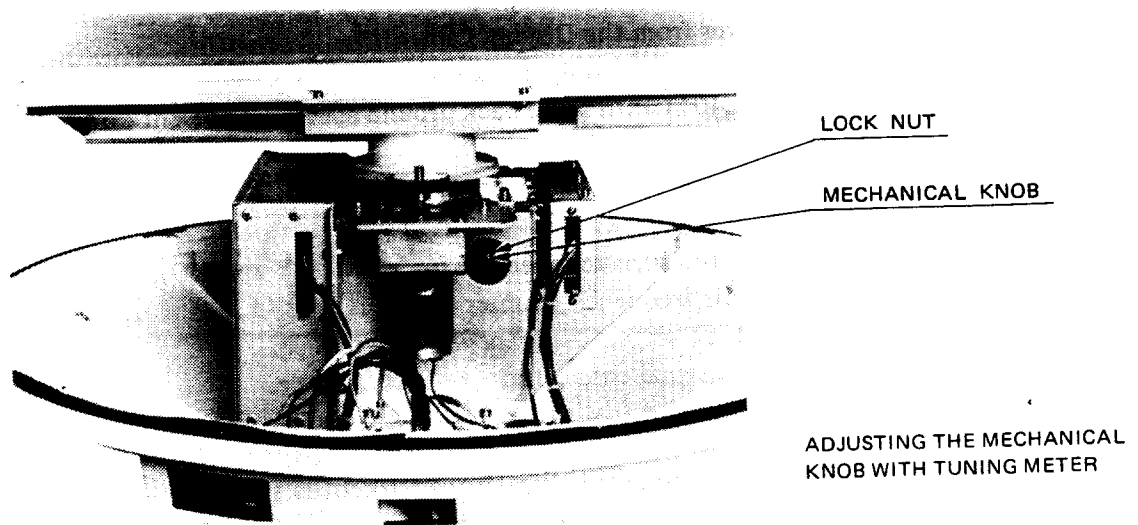

Fig. 5-1 GUNN OSCILLATOR TUNING

- 2) Beam centering adjustment on the CRT (*See Fig. 5-2*)
 - a. Remove the cover from the Display Unit
 - b. Loosen the locking screw on centering magnet and rotate the two knobs simultaneously or individually so that the beam center coincides with the center of cursor line.
 - c. After adjustment, tighten the locking screw of centering magnet.

Note: A permanent magnet, is mounted behind the deflection coil and consists of two doughnut shaped plates.
- 3) Intensity adjustment
 - a. Remove the cover from the Display Unit.
 - b. **CRT BRIL** push highest position.
 - c. Adjust RV4 (INTENSITY ADJ) so that PPI is suitable brightness.
- 4) Focus adjustment
 - a. Remove the cover from the Display Unit.
 - b. Adjust VR203 (Display Sub PCB) so that the sweep line, rings and targets on the screen are as small and clear as possible.

- 5) Comparator level Adjustment
 - a. Remove the cover from the Display Unit.
 - b. Rotate the GAIN control fully clockwise.
 - c. Adjust RV2 (PC401) until some back ground speckle is present on the screen.

- 6) Display Assembly adjustment
 - 6-1) H-Hold
 - a) Disconnect the signal connector (for VSY, HSY and VD).
 - b) Loose couple frequency counter to L571(D.Y)-1.
 - c) Adjust VR501 so that frequency is 15.625 kHz.
 - d) Connect the signal connector.

 - 6-2) V-Hold

Adjust VR401 so that vertical screen is kept in sync..

 - 6-3) H-Width
 - a) Set RANGE switch at 12 nm.
 - b) Adjust L502 so that the fourth marker is 1/16" from the CRT edge.

 - 6-4) V-HEIGHT and V-LIN
 - a) Set RANGE switch at 12 nm.
 - b) Adjust VR402 and VR403 so that the marker is round.

 - 6-5) CRT BIAS
 - a) Rotate VR201 (contrast) fully counterclockwise.
 - b) Adjust VR502 so that the raster on the screen is dimly seen.
Caution: VR502 carefully to avoid CRT damage.
 - c) Rotate VR201 ADJ clockwise for best contrast.

- 7) Panel dimmer Adjustment

Adjust RV401 so that the switch panel is suitable brightness.

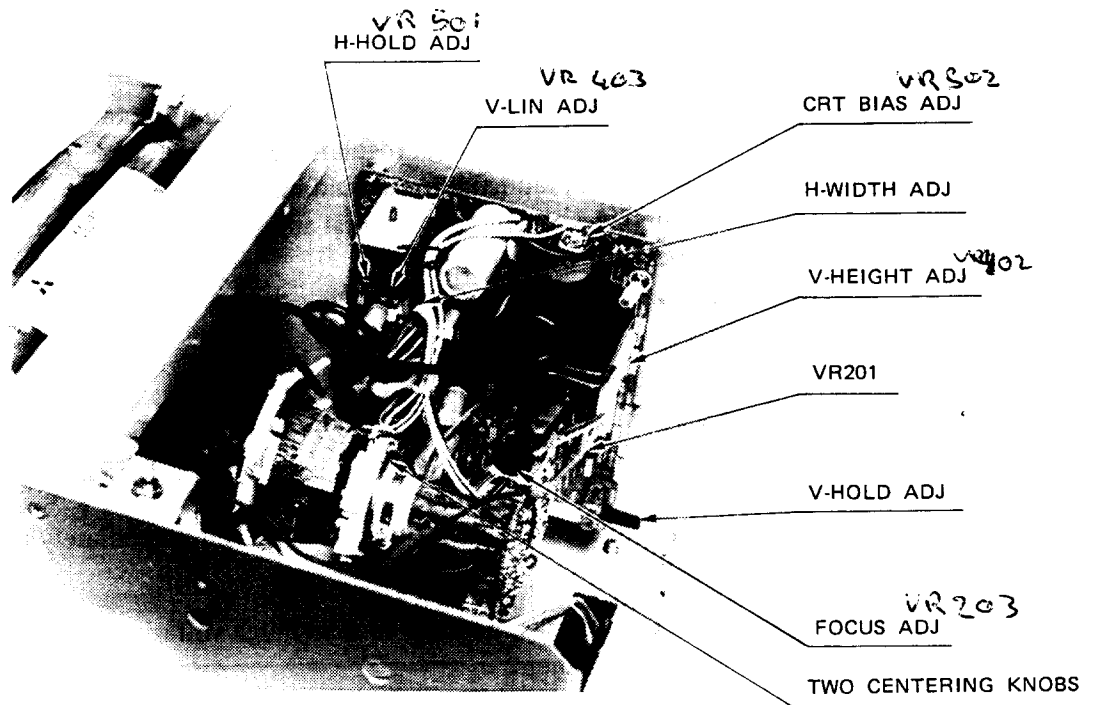

FIG. 5-2 BEAM CENTERING AND DISPLAY ADJUSTMENT

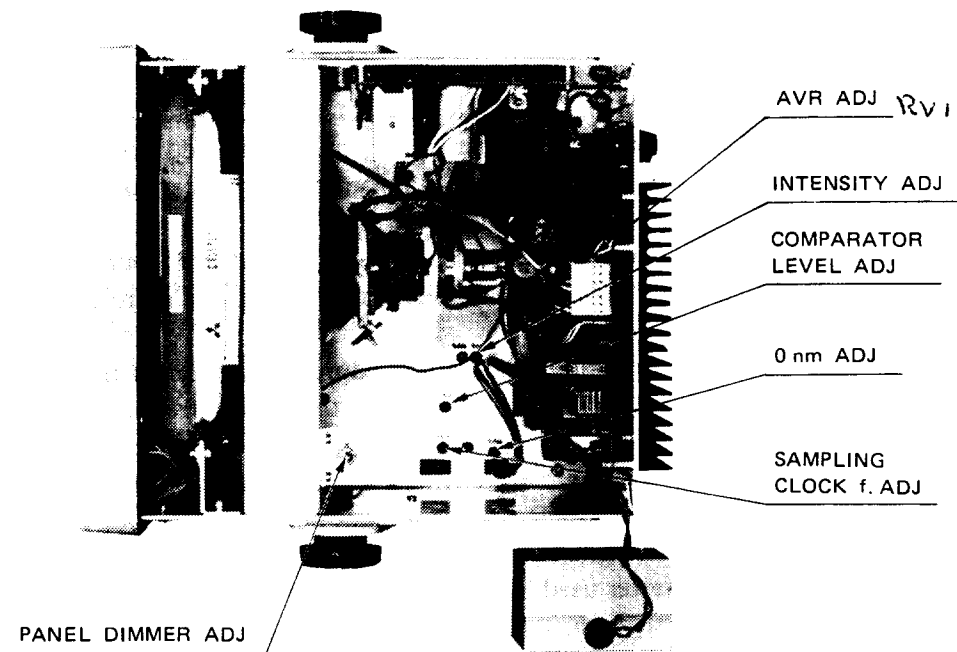

FIG. 5-3 DISPLAY UNIT ADJUSTMENT

TABLE 5.1 SPARE PARTS

Name of Parts	Type	The number of articles	Description	Supplier	Code No.
Diode	IN23E	1	CD301 Receiver unit		5TXAJ00009
Diode	IN23ER	1	CD302 Receiver unit		5TXAJ00010
Lamp		2	PL401 Display unit PL402	Arrow	5TWAAB00232
Fuse	Glass tube 7A	2	F401 Display unit	Toyo fuse	5ZFAD00019
	Glass tube 3A	2	F401 Display unit	Toyo fuse	5ZFAD00016

TABLE 5.2 OPERATION CHECK LIST

Unit to be checked	Check item	Correct condition	Remarks	Measuring point
Scanner Unit	a. Tune	Maximum indication	5 ~ 10Vdc range of the tester	TB101 32
	b. Mag. current	12 V		TB101 MO
Display Unit	a. Input voltage	Refer to Note		F501 ~ 2A (PC501)
	b. AVR output voltage	17 V		1G ~ 2A (PC501)
	c. Observation of screen sensitivity, sweep length, sweep linearity, sweep center, ring and illumination.			N/A
	d. Check of the operating controls			

Note: Allowable variation of input voltage.

dc 12V: 11V ~ 16V
 dc 24V: 22V ~ 32V
 dc 32V: 28V ~ 42V

TABLE 5.3 FUSES USED

Location	Part No.	Rating current	Protective cct.	Type	Remarks
Display unit	F401	7A	All cct	Glass tube 7A	dc 12V
	F401	3A	All cct	Glass tube 3A	dc 24V, 32V

TABLE 5.4 TROUBLE SHOOTING GUIDE

Trouble	Remedy
1. Does not start at OPERATE switch to STBY.	Check: <ul style="list-style-type: none"> ○ Blown fuse F401. ○ Check input power circuits. ○ Fault of contact on S401. ○ Fault of TR501, 502, 503. ○ Fault of AVR cct on PC501. ○ Fault of contact on connector of PC501. ○ Fault of rectifier diodes on PC501.
2. Ready lamp not glowing.	Check: <ul style="list-style-type: none"> ○ AVR Inop. ○ Fault of CD401. ○ Fault of timer cct on PC401.
3. Scanner fails to rotate.	Check: <ul style="list-style-type: none"> ○ Fault of S101. (Safety Switch OFF) ○ Fault of contact on terminal boards. ○ Fault of B101 (Commutator and blush). ○ Fault of drive mechanism.
4. Scanner rotates but rotation of sweep is abnormal	Rotation of M101 and fault of connection between M101 (PG) and PC401. Check: <ul style="list-style-type: none"> ○ Fault of connection between M101 (PG) and PC401. ○ Fault of M101. ○ Fault of cct on PC401.
5. No picture on the screen.	Fault of CRT display unit or its supply voltages. Check: <ul style="list-style-type: none"> ○ Open heater of CRT. ○ Fault of contact on CRT socket. ○ Fault of contact on CRT cap. ○ Fault of video cct on PC401. (Fault of RV4) ○ Fault of timer cct on PC401
6. Only horizontal line screen.	There may be fault in vertical sweep generator, amplifier circuits and deflection coil. Check: <ul style="list-style-type: none"> ○ Fault in vertical sweep generator, amplifier cct (circuit).
7. Incorrect sweep <ul style="list-style-type: none"> ○ Start of sweep is not centered on the screen. ○ Markers are oval. 	<ul style="list-style-type: none"> ○ Adjust MT401 ○ Adjust horizontal or vertical hold. ○ Adjust vertical length and linearity.

Trouble	Remedy
8. No range rings on the screen.	Check: <ul style="list-style-type: none"> ○ Fault of range rings generator cct on PC401. ○ Fault of control cct on PC402.
9. Range rings on the screen but no noise and no echoes:	Faulty circuit between IF amplifier of receiver unit and input circuit of display unit video amplifier. Check: <ul style="list-style-type: none"> ○ Fault of GAIN, STC control settings. ○ Fault of receiver unit. ○ Fault of contact on terminal boards and connector. ○ Fault of GAIN, STC cct on PC401.
10. Noise and range rings on the screen but no echoes.	If no transmission is present, check the modulator and magnetron. Check: If transmission appears to be present as indicated by the correct MAG. I reading on Tester. TB101 MO = 12 VDC <ul style="list-style-type: none"> ○ Failure of Gunn Oscillator tuning. If transmission appears to be present, carry out the Gunn Oscillator tuning procedures and check the diodes. <ul style="list-style-type: none"> ○ Fault of Gunn Oscillator. ○ Fault of CD301, 302. If no transmission is present, <ul style="list-style-type: none"> ○ Whether the lead wire to magnetron is contacted to chassis. ○ Fault of magnetron.
11. Poor sensitivity. Dim echoes.	Check: <ul style="list-style-type: none"> ○ Reduction of transmitting output power. ○ Fault of magnetron. <ul style="list-style-type: none"> → Check of MAG. I reading on TB101-MO. ○ Fault of diodes (CD301, 302) ○ Fault of CRT. ○ Water in the radiator and waveguide. (Dirt, caked salt, ice and snow on the radome?) ○ Failure of Gunn Oscillator tuning. ○ Failure of FOCUS adjustment. ○ Failure of INTENSITY ADJ. ○ Fault of video amplifier cct on PC401. ○ Fault of receiver unit.

TABLE 5.5 TYPICAL VOLTAGES AND RESISTANCES

(A) Inter-unit terminal board

Note: Resistance measurements shall be made under the following conditions:

OPERATE switch-OFF, **S101** -ON.

Resistance value shall be measured between measuring point and ground unless otherwise specified, and negative terminal of the tester is grounded as a rule.

The tester used this measurement is 20 k Ω /V dc, 8 k Ω /V ac.

Voltage measurement shall be made under the following conditions:

OPERATE switch-ON, **RAIN CLUTTER** switch-OFF, **GAIN** -max, **SEA CLUTTER**

-min.

Ship's power supply is dc 12V.

SCANNER UNIT

Measuring Point	Resistance (Ω)	Voltage (V)							Remarks
		0.25 nm	0.5 nm	1 nm	2 nm	4 nm	8 nm	12 nm	
TB101 MH	22	340	340	340	340	330	330	330	DC 1200 V
MI	78	0.02	0.02	0.02	0.02	0.02	0.02	0.02	DC 0.3 V
PI	300	12	12	12	12	0.8	0.8	0.8	DC 30 V
6	6	12	12	12	12	12	12	12	DC 30 V
GS	53	4.7	4.7	4.7	4.7	4.7	4.7	4.7	DC 12 V
VD	55	0.13	0.13	0.13	0.13	0.13	0.13	0.13	DC 0.3 V
33	6.5 k	7	7	7	7	7	7	7	DC 30 V
38	600	5	5	5	5	5	5	5	DC 30 V
DP	460	7.5	7.5	7.5	7.5	7.5	7.5	7.5	AC 30 V

(B) Resistances at inter-unit connector without connection of cables.

NOTE: Refer to Note given in item (A).

SCANNER UNIT			DISPLAY UNIT		
Measuring Point		Resistance (Ω)	Measuring Point		Resistance (Ω)
TB101	MH	∞	J502	1	0
	TI	1 k		2	20
	PI	320		3	100
	6	8		4	0
	GS	3.5 k		5	0
	VD	∞		6	55
	33	80 k		7	6.5 k
	38	0		8	8.5
	DP	700		9	8.5
				10	630
			11	35	
			12	0	
			13	4.8 k	
			14	0	
			15	0	
			16	16	

DISPLAY UNIT

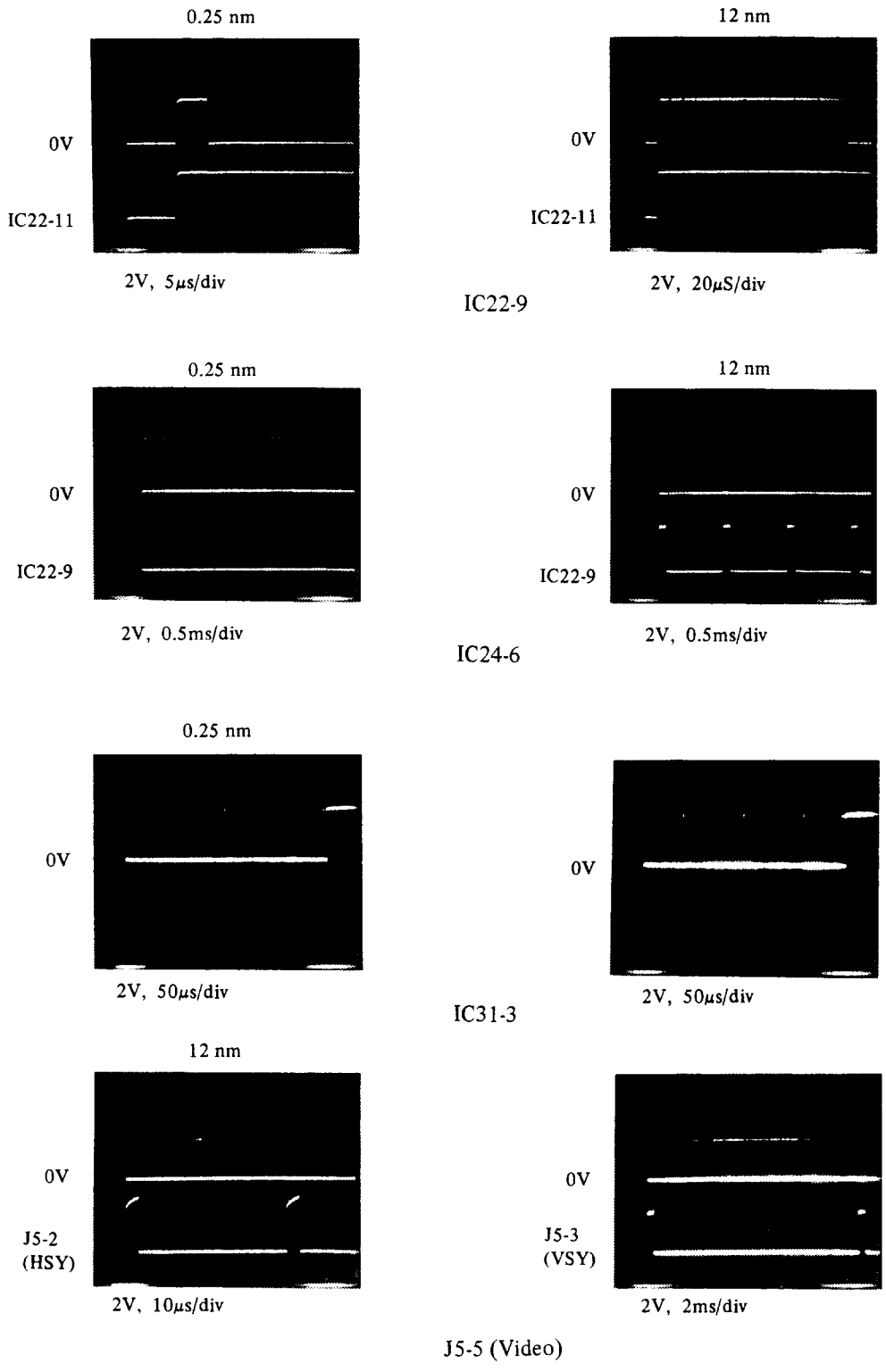
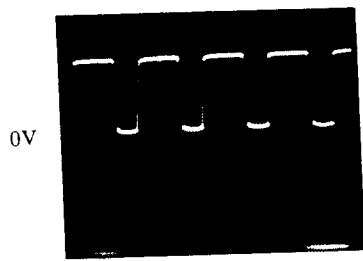
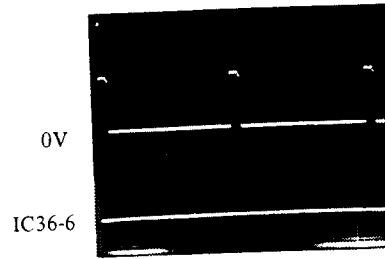

FIG. 5-4 TYPICAL WAVEFORMS - 1/2



2V, 0.5ms/div
J3-5 (CP)



2V, 0.5ms/div
IC21-13

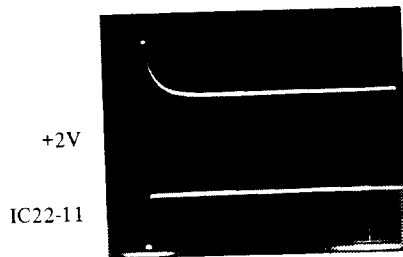

+2V
IC22-11

2V, 50µs/div
J3-9 (GS)

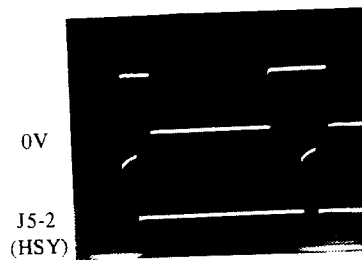

0V
J5-2 (HSY)

2V, 10µs/div
IC59-7

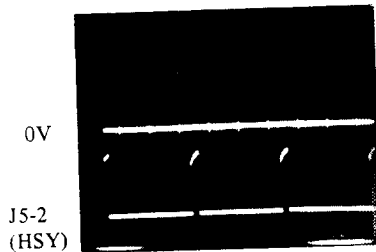

0V
J5-2 (HSY)

2V, 20µs/div
IC51-12

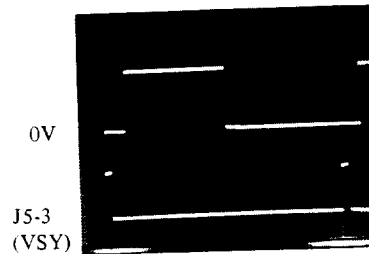

0V
J5-3 (VSY)

2V, 2ms/div
IC51-4

FIG. 5-4 TYPICAL WAVEFORMS - 2/2

5.3 REPLACEMENT OF MAJOR COMPONENTS

5.3.1 Replacement

(1) Magnetron V 201

- a. Remove 4 screws holding the transmitter unit.
- b. Remove the cover from chassis.
- c. Disconnect magnetron leads from the pulse transformer.
- d. Remove 4 screws holding the magnetron.
- e. Ease the magnetron away from the mounting plate and withdraw.
- f. To reassemble, reverse the above procedure.

CAUTION: Do not put the magnetron on iron plate.

(2) Diode Limiter A 102

- a. Remove 4 screws holding the Receiver Unit.
- b. Withdraw the Diode limiter.
- c. To reassemble, reverse the above procedure.
- d. To reassemble, reverse the above procedure.

(3) Gunn Oscillator A 301

- a. Remove 4 screws holding the the receiver unit.
- b. Disconnect leads from the Gunn Oscillator.
- c. Remove 4 screws holding the Gunn Oscillator.
- d. Withdraw the Gunn Oscillator from the Mixer.
- e. To reassemble, reverse the above procedure.

(4) Crystal diodes CD301, 302

- a. Remove 4 screws holding the receiver unit.
- b. Pull diodes out from their mounts.
- c. When replacing ensure that the diode polarity is correct.
- d. Pay sufficient care on handling diodes, since they are fragile to strong radio waves, high voltages and mechanical shocks.

(5) Cathode-ray tube V 401 (*See Fig. 5-5*)

- a. Remove the cover from the Display Unit.
 - b. Remove 4 knobs on the front panel.
 - c. Remove front panel.
 - d. Remove the socket from CRT base.
 - e. Remove the HV cap from CRT.
 - f. Remove 4 screws holding the CRT.
 - g. Remove the CRT frontward.
- To replace the CRT proceed as follows:
- h. Insert the CRT in position and orientate it so that HV cap is at 9 o'clock.
 - i. Place the CRT front panel on the tube face and tighten screws.
 - j. Replace HV cap and socket.
 - k. Then reverse above procedure c → b → a.

(6) Drive motor M 101 (*See Fig. 5-6*)

- a. Remove 4 screws holding the drive motor.
- b. Remove the drive motor from turning mechanism plate.
- c. To replace, reverse the above procedure.

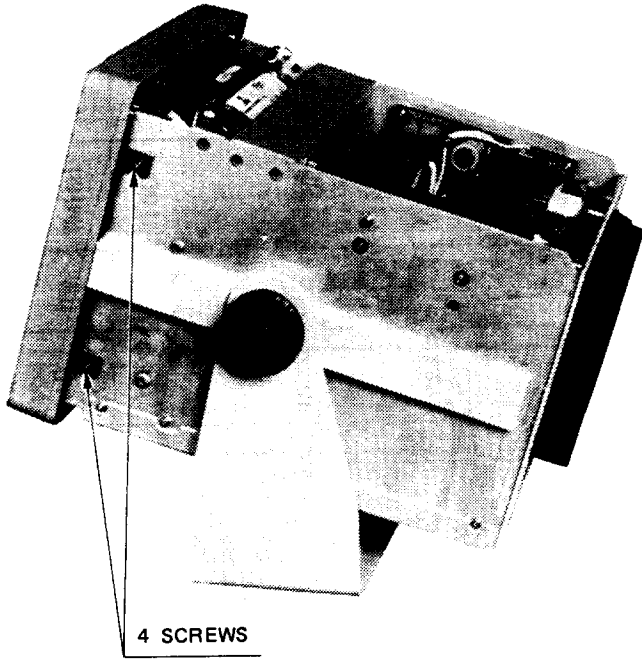

REMOVE 4 SCREWS SECURING
THE FRONT PANEL

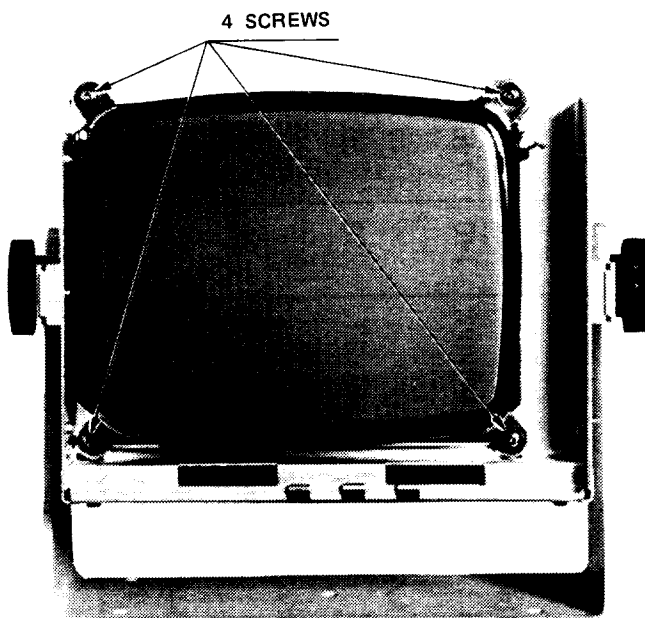

REMOVE 4 SCREW
and
REMOVE THE CRT
FRONTWARD

Fig. 5-5 REPLACEMENT OF CRT

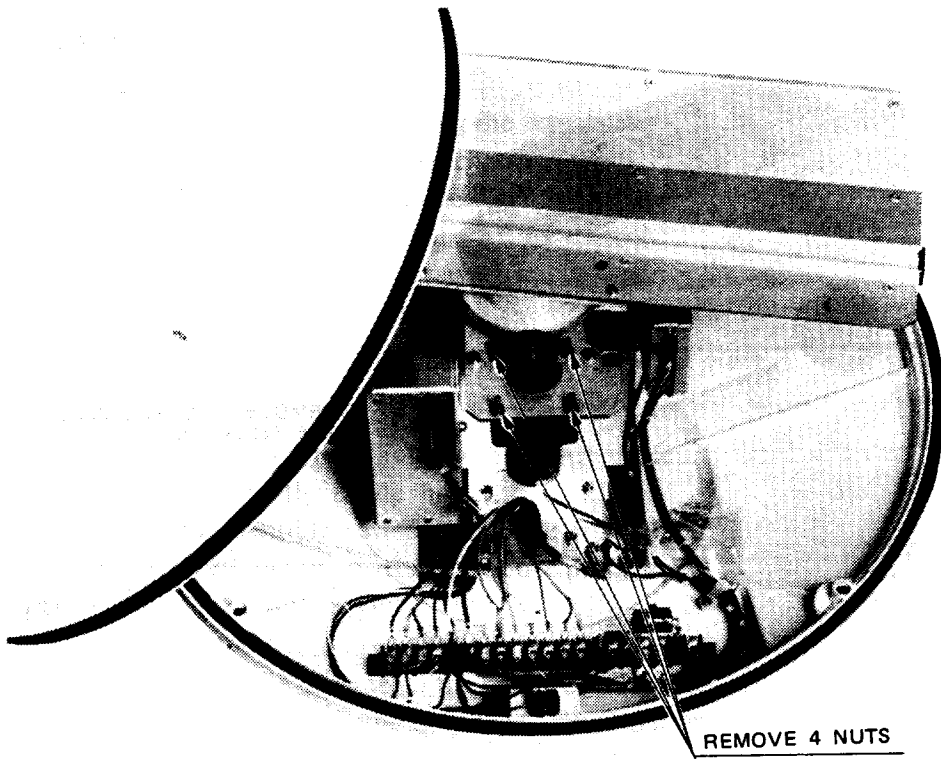

Fig. 5-6 REPLACEMENT OF DRIVE MOTOR

TABLE 5.6 TABLE OF TRANSISTORS USED

Type	Kind, Use	Supplier	V _{cb0} (V)	V _{ce0} (V)	V _{eb0} (V)	I _c	P _c	h _{FE}	V _{ce} (V) (sat)	V _{be} (V) (sat)	h _{fe}	f _r (MHz)	Q _{at} (°C/W)
2SC1212AB	Si HF Driver NPN	Hitachi	80	80	4	1A	8 W	60 ~ 120	1.0	1.5		160	
2SA1015-Y	Si AF Amp PNP	Toshiba	-50	-50	-5	-150 mA	400 mW	120 ~ 240	-0.3 max	-1.1 max		80 min	
2SC1855	Si HF Amp NPN	Hitachi	20	20	3	20 mA	250 mW	20 ~ 200				550	
2SD1148-O	Si NPN	Toshiba	140	140	5	10A	100 W		2.0 max				
2SC1815-Y	Si AF Amp NPN	Toshiba	60	50	5	150 mA	400 mW	120 ~ 240	0.25 max	1.0 max		80 min	
2SD633Z	Si NPN	Toshiba		100	5	7 A	40 W		2.0 max	2.5 max			
2SA839-O	Si HF Amp PNP	Toshiba	-150	-150	-5	-1.5A	25 W	70 ~ 140				6	

TABLE 5.7 TABLE OF DIODES USED

Type	Kind, Use	Supplier	V _{RM} (V)	V _R (V)	I _{PM} (mA)	I _O (mA)	P (mW)	V _F (V)	
1S1588	Si High Speed Switching	Toshiba	35	30	360	120	300	1.3	†
1S1832	Si Rectifier	Toshiba	1800	1500	2.5A	0.7A		2.0	
V06C	Si Rectifier	Hitachi	200			1.1A		1.4	
U05J	Si Rectifier	Hitachi	1000	800		2.7A		1.3	
HVR-3H	Si Rectifier	Sanken	8000			350		12	
S6080B	Thyristor	Toshiba	750						turn off time = 15 μs (I _T (AV) = 3A)
1K34A	Ge Detector	Unizon		60		50			
5D2Z11	Si Rectifier	Toshiba	200			5A			
1N60	Ge	New JRC	30	20		50			
S6K20	Si Rectifier	SHINDENGEN	200			6A		1.2	
5D2C11	Si Rectifier	Toshiba	200			5A			
U05C	Si Rectifier	Hitachi	300	200					
BZ-350	Si Zener	New JRC					1W		V _Z = 35 V

TABLE 5.8 TABLE OF INTEGRATED CIRCUITS USED

Type	Kind, Use	Supplier	Remarks
μ PC596C	VIF Detector	NEC	$V_{CC} = 15$ V, $P_D = 275$ mW ($T_a = 70^\circ$ C)
TA7124P	Linear, VIF Amp	Toshiba	$V_{CC} = 15$ V, $P_D = 400$ mW, $G_p = 48$ dB ($f = 58$ MHz) NF = 6.0 dB ($f = 58$ MHz)
μ PC71D	High Speed Comparator	NEC	$V^+ = 12$ V, $V^- = -6$ V $V_{IO} = 1.0$ mV, $I_{IO} = 1$ μ A $V_{OH} = +3.2$ V, $V_{OL} = -0.5$ V
TA7326P	Linear Timer	Toshiba	$V_s = 12$ V, $V_{CC} = 7$ V, $P_D = 400$ mW $T_{opr} = -20 \sim 75^\circ$ C
NJM4558D	Dual Operational Amp	New JRC	$V^+ = 15$ V, $V^- = -15$ V
μ PD416C-2	16384 BIT N CHANNEL MOS RAM	NEC	access time = 200 ns
μ PC494C	STABILIZED POWER SUPPLY	NEC	$V_{CC} = 41$ V $I_c = 250$ mA $V_{CER} = 41$ V $P_T = 1000$ mW
HA17723G	STABILIZED POWER SUPPLY	Hitachi	$V_{CC} = 40$ V, $P_T = 1000$ mW, $I_{out} = 150$ mA
HA17555PS	Precision Timer	Hitachi	$V_{CC} = 18$ V $I_{source}, I_{sink} = 200$ mA

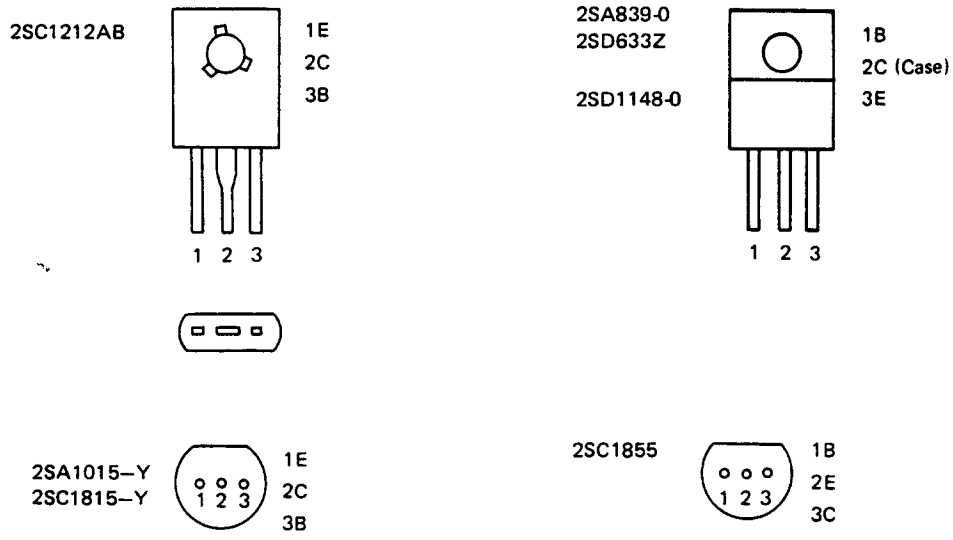

FIG. 5-7 IDENTIFICATION OF TRANSISTOR LEADS

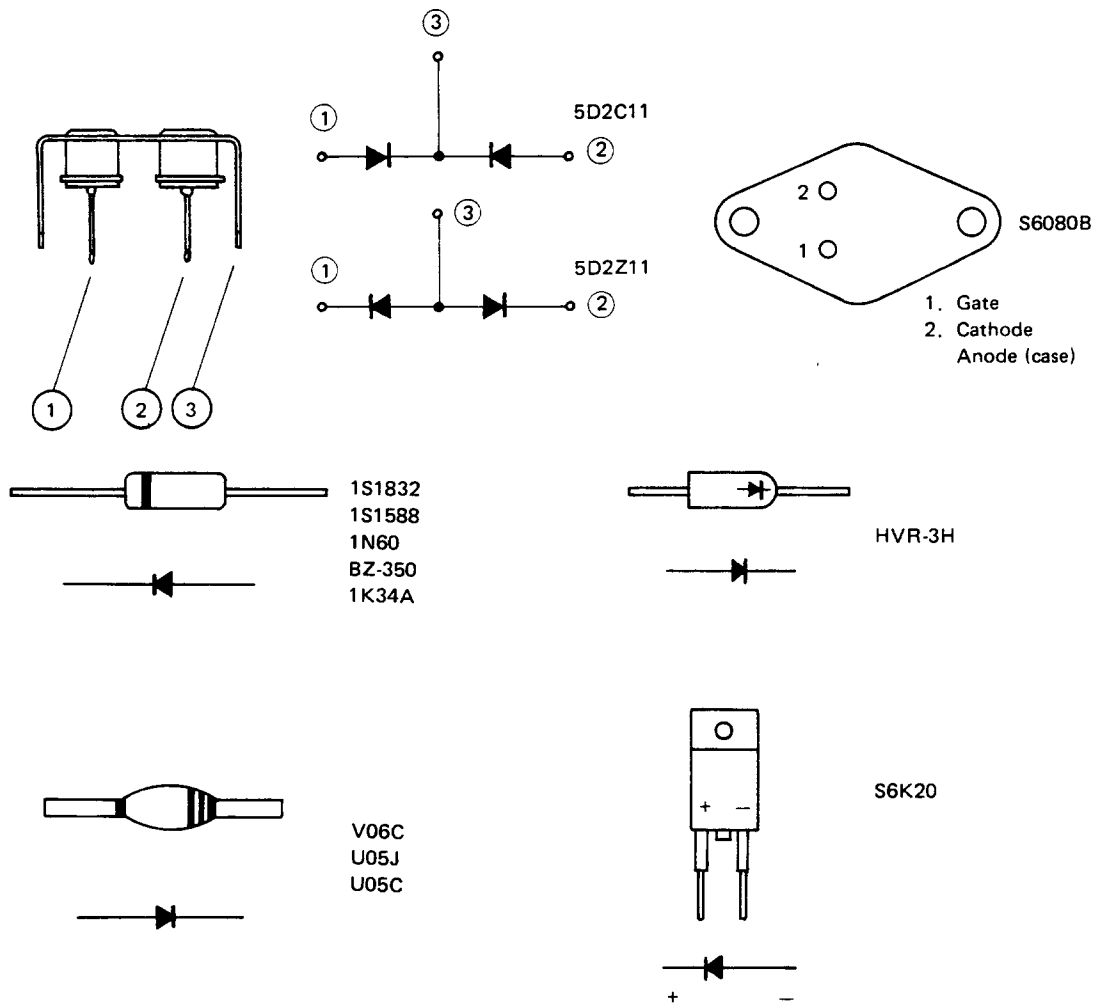
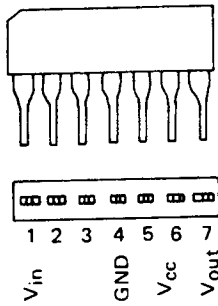
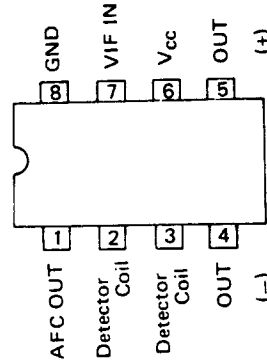

FIG. 5-8 IDENTIFICATION OF DIODE LEADS



TA7124P



μPC596C

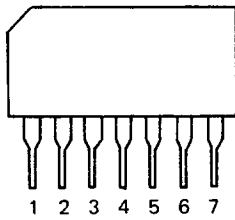

TA7326P

- 1. VS
- 2. RESET
- 3. START
- 4. GND
- 5. VCM
- 6. OUTPUT
- 7. VDD

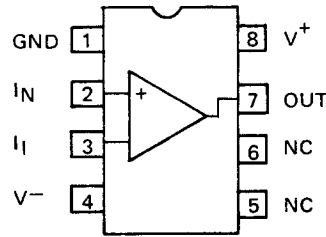

μPC71D

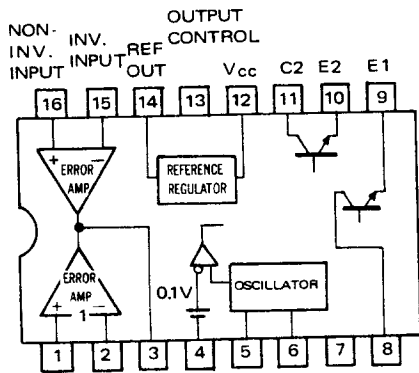

- 1. NON-INV. INPUT
- 2. INV. INPUT
- 3. REF. OUT
- 4. DEAD-TIME FEED-BACK
- 5. CT
- 6. RT
- 7. GND
- 8. C1
- 9. E1
- 10. E2
- 11. C2
- 12. Vcc
- 13. REF. CONTROL
- 14. INV. INPUT
- 15. NON-INV. INPUT
- 16. OUTPUT CONTROL

μPC494C

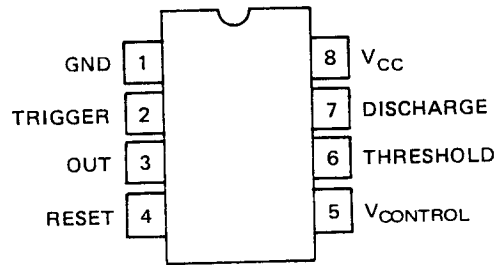

HA17555PC

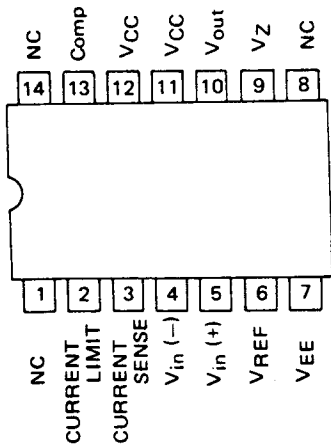

HA17723G

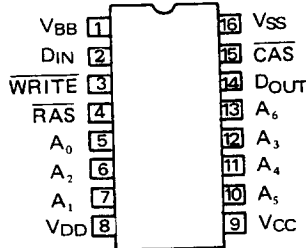

μPD416C-2

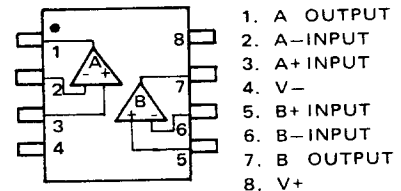

NJM4558D

FIG. 5-9 IDENTIFICATION OF IC (TOP VIEW)

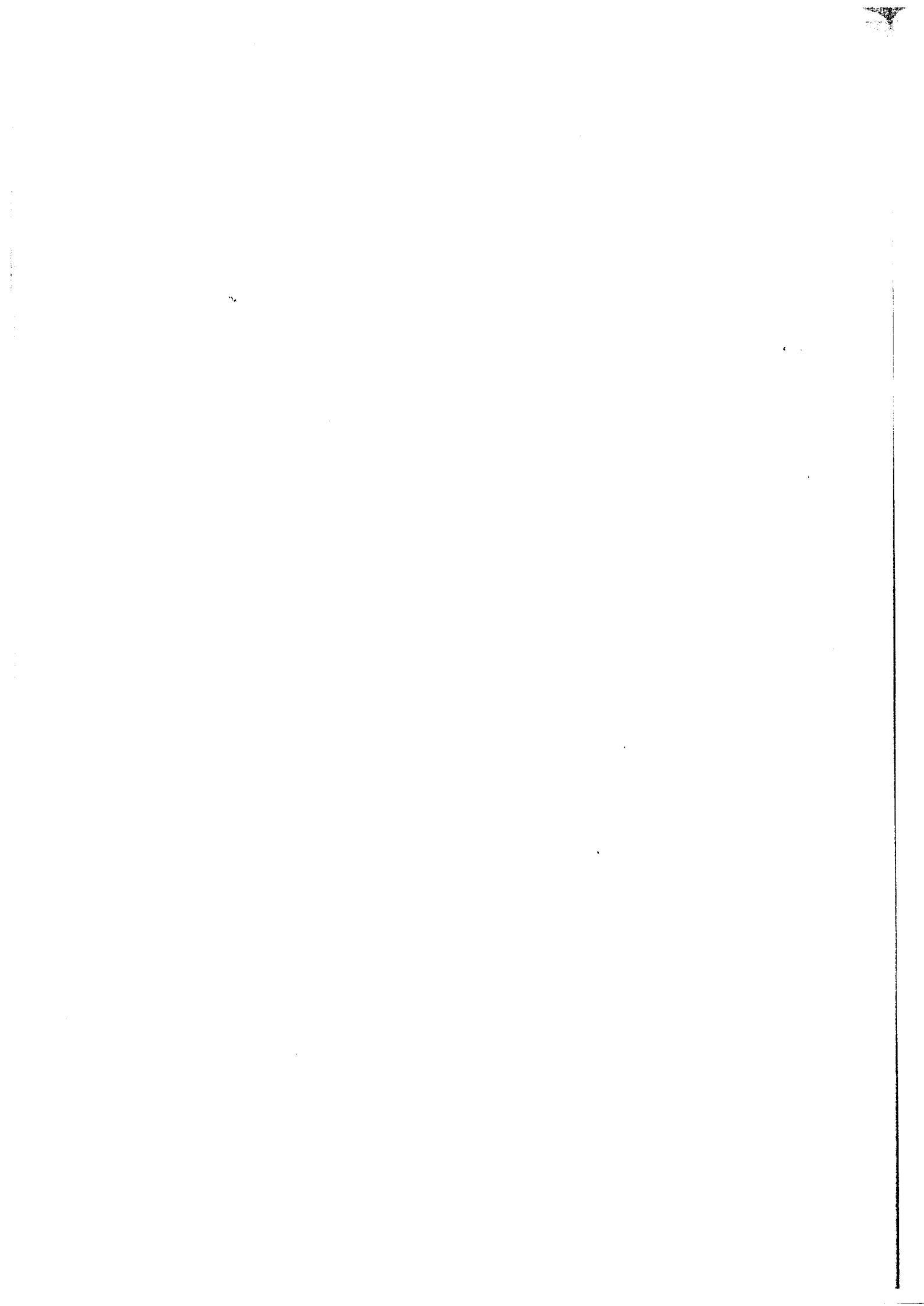

SECTION 6

TECHNICAL DESCRIPTION

6.1 BLOCK DIAGRAM DESCRIPTION

- 6.1.1 General
- 6.1.2 Scanner Unit
- 6.1.3 Display Unit

6.2 SCANNER UNIT

- 6.2.1 Radiator, Motor-encoder, Radiator Rotating Mechanism, SHM Sw.
- 6.2.2 Transmitter
- 6.2.3 Receiver

6.3 DISPLAY UNIT

- 6.3.1 General
- 6.3.2 Main Control Circuits

6.1 BLOCK DIAGRAM DESCRIPTION

6.1.1 General

The overall system block diagram can be considered as being comprised of two main sections. One for the scanner unit circuit diagram; the other for the display unit circuit diagram. The following description of the block diagram explains the individual circuits described in Chapter 6.2 and 6.3.

The motor-encoder and SHM pulse generator are used to synchronize; the bearing of the radar display, display timing and transmit-triggering. Setting the operate switch to "STBY" position activates the power supply which in turn provides operating voltages to all circuits of the radar. After about 90 seconds, setting the operate switch to "ON" position allows transmitter triggering and the radar becomes operational.

6.1.2 Scanner Unit

The scanner unit includes the scanner drive mechanism together with the transmitter and receiver. These three sections are housed within a 25" radome.

1) Radiator

The radiator is a horizontally polarized, resonant, center-fed slotted wave guide array. The radiator is driven at 27 rpm by a motor-encoder via a reduction mechanism.

2) Motor-encoder

The scanner motor is a dc motor which incorporates a reduction mechanism and encoder. The input voltage of the motor is 12 V dc. The encoder generates a bearing sync pulse every 0.176 degree or 2048 pulses for each complete rotation of the scanner.

3) SHM Pulse Generator

The SHM pulse generator consists of a reed switch and permanent magnet which is mounted on the main reduction gear. The SHM pulse resets the bearing counter in the display unit to zero.

4) Modulator

A line-type pulser is used in the modulator. The charging method used is dc charging. A silicon controlled rectifier (SCR) is used as the high power switch of the pulser.

The pulse selection relay (K201) is controlled by the RANGE switching on the control panel of the display unit. This will provide short pulses when the 0.25, 0.5, 1 or 2 nm range switches are selected and long pulses on the 4, 8 or 12 nm ranges. The pulse repetition frequency (PRF) rate is 920 Hz.

5) Magnetron Transmitter

A voltage of the required pulse width is fed to the magnetron which generates high energy oscillations in the region of 9445 MHz for the duration of the input pulse. The operating point of magnetron is at a voltage of -3.6KV and a current of 3A.

6) Circulator and Diode Limiter

A ferrite circulator is used for the duplexer. The Passive Diode Limiter is used to protect the receiving section (especially the mixer diodes). From excessive RF input levels at all times.

7) Gunn Oscillator

A Gunn Oscillator is used for the local oscillator. The oscillator generates a low energy RF signal the frequency of which is tuned 38 MHz higher than that of the transmitter output frequency.

8) Mixer

Two small diodes, fitted inside the mixer waveguide assembly at the receiver input, form a balanced mixer which feeds the intermediate 38 MHz frequency signal to the I.F. amplifier.

9) I.F. Amplifier

The I.F. amplifier consists of two stages. The first stage is a low noise transistor amplifier; the second is a linear integrated circuit amplifier stage. The second stage is controlled by the GAIN-SEA CLUTTER signal from the display unit.

10) Detector

In this stage, the I.F. (38 MHz) component is removed leaving video rate signals for display.

11) Video Circuit

This circuit is primarily an emitter follower which feeds the video signal from the detector to the display unit providing an impedance match to the coaxial cable. At the same time this emitter follower supplies the video integrator circuit used for tuning of the Gunn Oscillator.

6.1.3 Display Unit

The display unit consists of the main control circuits, the control panel circuitry, the CRT display and the power supply.

The display unit is fed with the video and bearing synchronizing signals from the scanner unit via a multicore cable. Semi-conductors and integrated circuits are used throughout the display except for the CRT and lamps.

1) Video Circuit

The video circuit consists of the FTC (Rain-Clutter) circuit, inverting amplifier, D.C. restorer circuit, emitter follower and tuning indicator circuit.

2) Comparator

The comparator generates a digital pulse train from the input analog video signal. Comparator level adjust RV402, sets the video threshold.

3) Pulse Stretch

The pulse stretch circuit expands the width of the digital video pulses, according to the range scale selected.

4) Buffer Memory

The buffer memory stores the video data of 3 successive transmissions. A single transmission of video data is stored into 112 memory cells.

5) Interference Rejecter

The stored transmissions of video data from the buffer memory is serially fed into the interference rejecter. Interference in the video data will be rejected using pulse correlation techniques.

6) Video RAM

The Video RAM is the main memory for the display. The display area on the CRT screen is divided by 224 x 224 dots, the Video RAM used in the 1200 Radar has 65,536 memory cells (256 x 256).

7) Gate Generator

The gate generator produces a waveform whose duration depends on the setting of the RANGE switches. The output gate is fed to the sampling clock oscillator.

8) Sampling Clock OSC

The sampling clock oscillator produces the sampling clock pulse, (17.5 MHz) which is the sampling frequency of 0.25 and 0.5 nm ranges.

9) Count Down

The count down circuit produces the sampling clock pulses for the remaining ranges (1 to 12 nm ranges). The countdown circuit consists of four divided by 2 circuits and one divided by 3.

10) Sampling Clock Select

The sampling clock select circuit selects the proper sampling clock pulse rate via the range data signal from the control circuit PCB. The output is fed to the R/W clock select circuit.

11) R/W Clock Select

The read/write clock select circuit selects either the pulses from the sampling clock pulse or the display clock pulses of H. counter depending on the appropriate timing of sampling or displaying. The output is fed to the buffer memory address counter.

12) Memory Address Counter

The memory address counter produces the buffer memory address data and controls reading and writing of the buffer memory.

13) \bar{W} Pulse Generator

The \bar{W} pulse generator produces the writing pulses to the Video RAM from the output of the X address counter.

14) Parallel-Serial Converter

The parallel-serial converter circuit changes the four bits data of the Video RAM to the serial data.

15) Bearing Pulse Generator

The bearing pulse generator synchronizes the signal of the motor encoder into the display timing. The output of this circuit is fed to the bearing counter circuit and the main trigger generator circuit.

16) Main Trigger Generator

The main trigger generator circuit produces the trigger pulse for the transmitter and display control timing.

17) Transmitter Trigger Generator

The transmitter trigger generator produces the pulse for driving the modulator in the scanner unit.

18) Delay Circuit (0 nm Adjust)

The delay circuit produces a variable delay time for adjusting the PPI center to 0 nm as compensation for transmitter firing delays.

19) Gain-STC (Sea Clutter) Circuit

The Gain-STC circuit controls the sensitivity of the receiver in response to the setting of the Gain and Sea Clutter controls on the control panel. At sea, the effect of random signals received from waves at short ranges can be reduced with the sea clutter control.

20) Clear Pulse Generator

The clear pulse generator produces the pulse for resetting the bearing counter to zero. The Clear Generator is triggered by the SHM Pulse.

21) Bearing Counter

The bearing counter produces the antenna position data from the motor-encoder output and the SHM signal in the scanner unit.

22) RO/XY Converter

The RO/XY converter circuit produces the pulse train for changing the bearing data and the range data into the X and Y address data.

23) X Address Counter

The X address counter produces the X address data for writing the Video RAM.

24) Y Address Counter

The Y address counter produces the Y address data for writing the Video RAM.

25) Marker Generator

The marker generator produces two marker pulses at 0.25 and 0.5 nm ranges and four marker pulses at 1, 2, 4, 8 and 12 nm ranges for input to the Video RAM.

26) Address Data Select

The address data select circuit inputs 7 bits X/Y counter address data or H/V control data to the Video RAM address (depending on timing of read/write), ROM address, latch and/or column address latch to the Video RAM address.

27) Master Oscillator

The master oscillator produces the 6 MHz clock pulse for the CRT display and the system control.

28) Horizontal Counter

The horizontal counter produces the X address data at the display time from the clock pulse of the master oscillator.

29) Vertical Counter

The vertical counter produces the Y address data at the display time from the output of the horizontal counter last stage.

30) Horizontal and Vertical Synchronizing Pulse Generator

This circuit produces the pulses for synchronizing horizontal and vertical deflection of the CRT display unit.

31) SHM Generator

The SHM generator produces the pulses for displaying the ship's heading marker on the screen.

32) 90 Sec Timer

The 90 Sec Timer circuit provides the delay time which is required for warm up of the magnetron.

33) SHM Mixing, Blanking Gate

The SHM Mixing circuit is used for mixing the video pulses and the SHM pulses. The blanking gate circuit switches the mixed signal by display timing.

34) Video Buffer

The video buffer circuit controls the CRT intensity according to the BRIL SW setting on the front panel and drives the video circuit of the CRT display unit.

35) Display PCB

The display PCB contains the horizontal deflection circuit, the vertical deflection circuit and the power supply circuit for the display unit which is supplied from 12 V dc.

36) Video PCB

The video PCB contains the final video amplifier circuit for driving CRT cathode.

37) Control Panel Circuit PCB

The control panel circuit produces the signals for controlling the display circuitry by setting control knobs and control switches on the front panel.

38) AVR Circuit

The AVR circuit generates a regulated output voltage of 17 V dc from the ship's mains of 12 V, 24 V, or 32 V dc.

39) Converter Circuit

The converter circuit converts the 17 V dc output of AVR into four levels of voltage which are required for the scanner and the display unit operation. The outputs are -5 V, +5 V, +12 V, and +330 V dc.

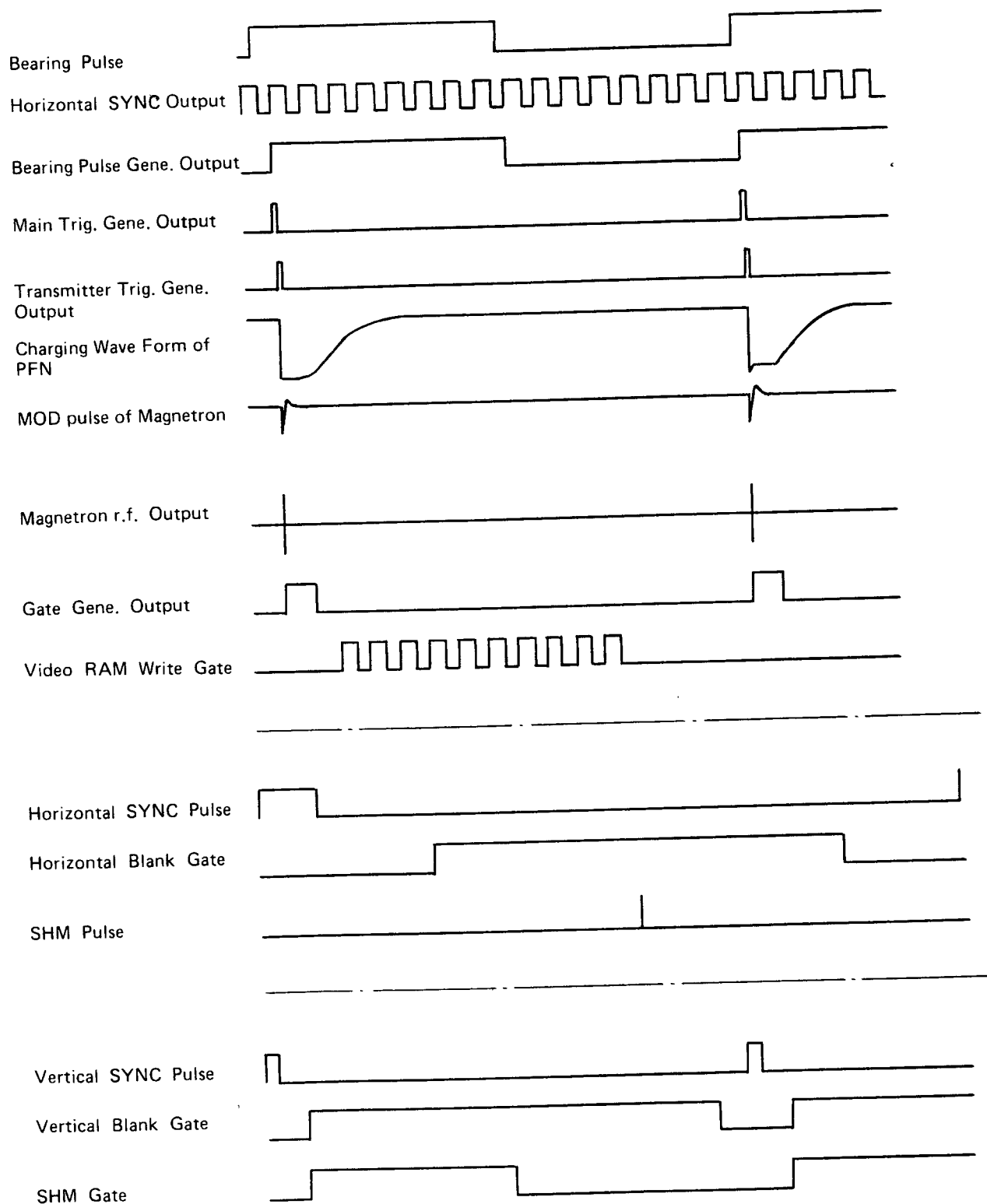
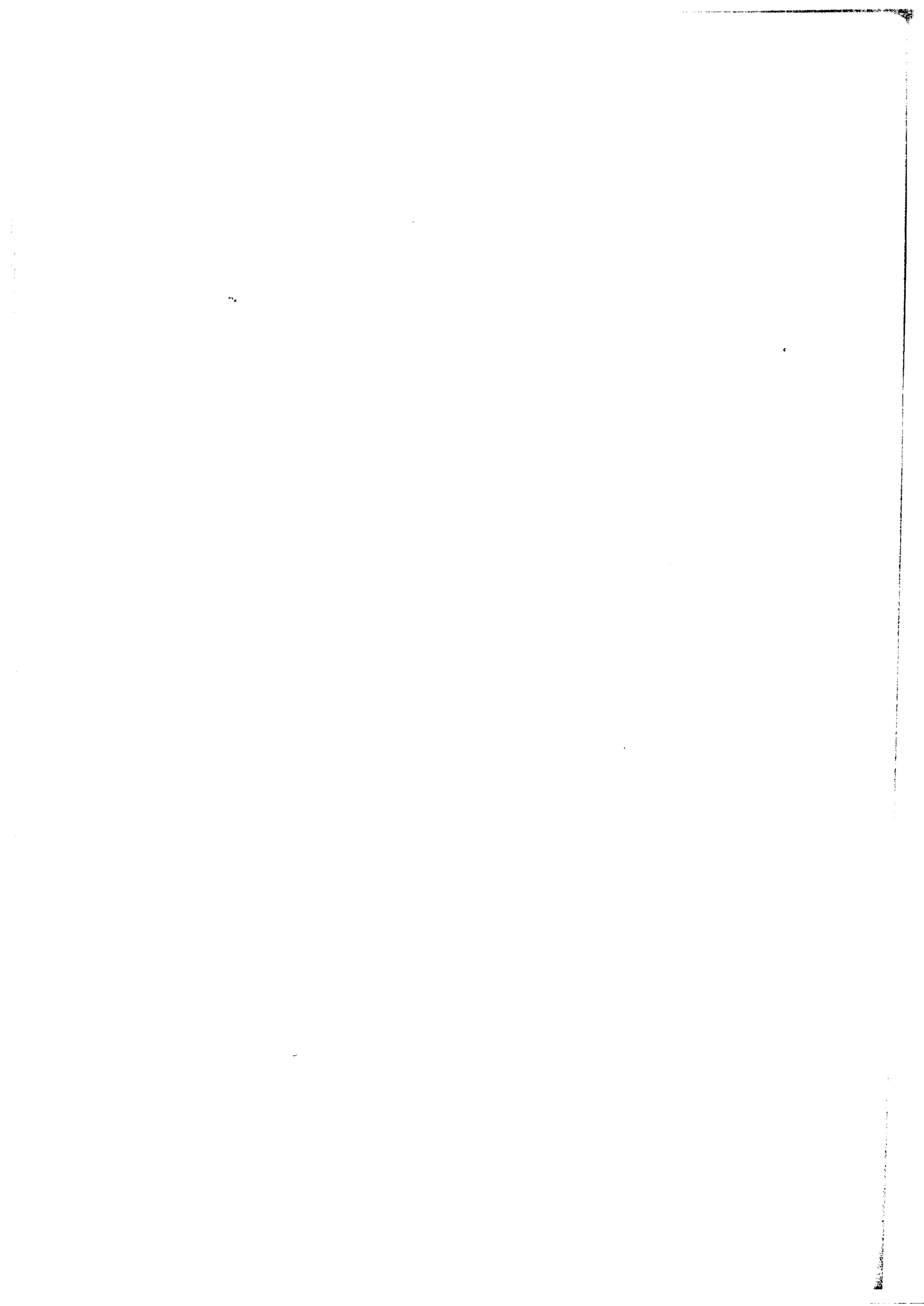
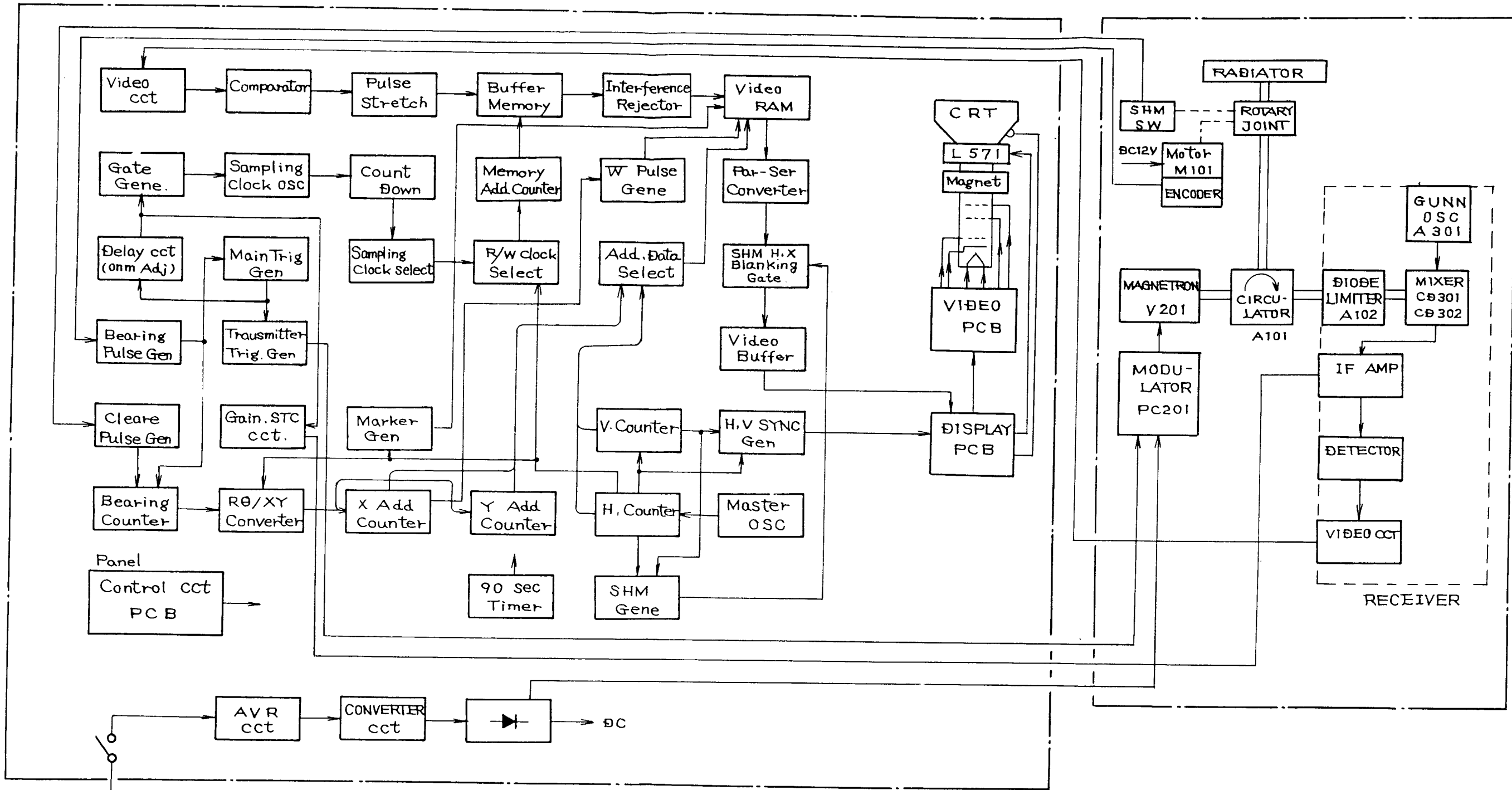

FIG. 6-1 OVERALL TIMING TABLE



M 8 9 3 6 1 DISPLAY UNIT

M 8 9 3 6 2 SCANNER UNIT



SHIP'S MAINS
DC: 2, 24, 32V

BLOCK DIAGRAM OF 1200 RADAR

6.2 SCANNER UNIT

The scanner unit consists of the radiator, the motor-encoder, radiator rotating mechanism, SHM sw, transmitter and receiver units. These components are housed within the 25" radome.

6.2.1 Radiator, Motor-encoder, Radiator Rotating Mechanism, SHM Sw

1) Radiator

The radiator is horizontally polarized, resonant, center-fed slotted waveguide array which is constructed in an aluminum flare. The radiator, approximately two feet in length is coupled to the transmitter and receiver via a short waveguide, rotary joint and circulator.

At half power points horizontal beamwidth is 5° and vertical beamwidth is 25° . Side lobes are better than -21 dB with respect to the main beam. The direction of maximum radiated power is perpendicular to the radiator. (Figure 6-2)

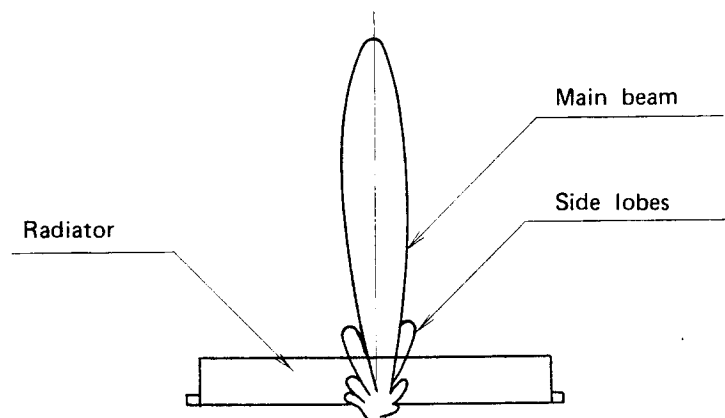

FIG. 6-2 RADIATOR PATTERN

2) Motor-Encoder

A 12 V dc motor is used to rotate the radiator. The encoder section of the assembly produces the bearing pulses for the rotation synchronization. A bearing sync pulse is generated every 0.176 degrees of rotation (2048 pulses per 360°) at 12 V dc amplitude. These pulses are sent through TB101-DP to the Bearing Pulse Generator in the Display Unit.

3) Radiator Rotating Mechanism

Mechanical coupling between the radiator and the motor-encoder is affected by reduction drive mechanism. The motor rotates at approx. 27 rpm. The reduction ratio is 45 : 128.

4) SHM Sw

SHM Sw produces the signal of the ship's head position when the permanent magnet fitted on the main gear passes across Reed Switch S102. The resulting SHF signal is sent to the Clear Pulse Generator in the Display Unit.

6.2.2 Transmitter

The general layout for the transmitter is shown in Figure 6-3. The transmitter consists of the modulator printed circuit board and the magnetron.

1) Modulator

The line-type pulser is used in the modulator and consists of a charging choke, SCR switch, PFN and pulse transformer. The circuit is shown in Figure 107.

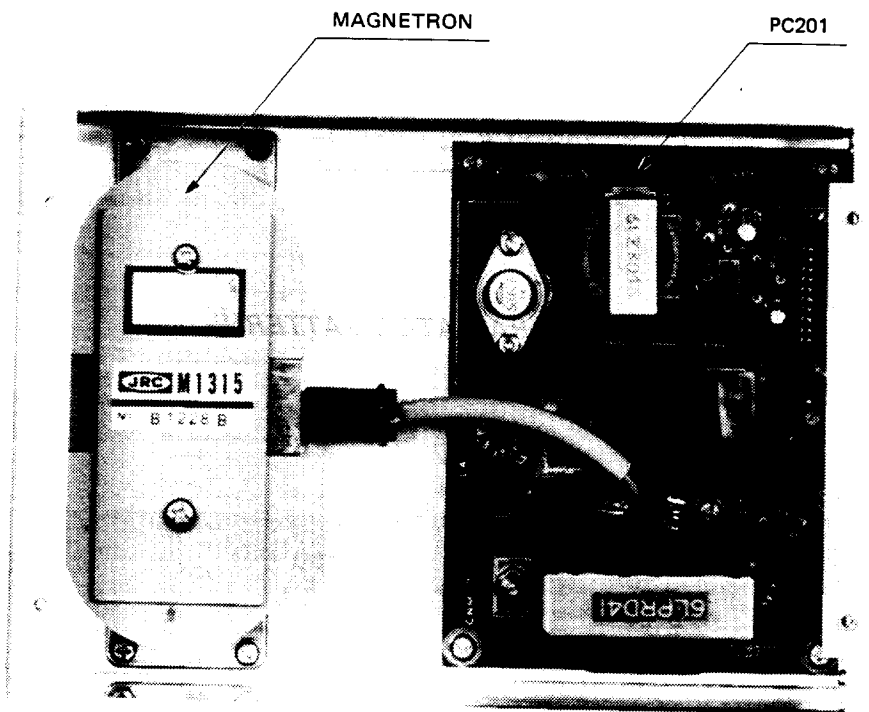

FIG. 6-3 TRANSMITTER UNIT

Circuit components:

L201 : Charging Choke
CD203 : SCR Switch
T201 : Pulse Transformer

and the PFN consists of L202, C204, C205, C206.

K201 is the pulse selection relay which is controlled by RANGE switches in the display unit.

By setting the OPERATE switch on the control panel to "ON" position, the modulator trigger pulse is fed to the base of TR1 from the transmitter trigger generator circuit in the display unit.

The MOD-MH of 330 V dc is fed to the PFN capacitors C204, C205 and C206 via L201. Because of the resonant charging action of L201, the PFN reaches almost twice the voltage of the input. Since the charging efficiency is approximately 90 %, the PFN voltage reaches nearly +600 V.

On receiving a positive pulse at the gate of CD203 from the emitter follower TR201 via R205, the SCR switch begins to conduct and the voltage which is charged across the PFN capacitor is discharged via CD203 and T201.

Consequently, the pulse determined by the PFN appears on the primary windings of the pulse transformer T201 and this pulse is stepped up to the cathode of the magnetron via T201 (approximately 1 : 13).

The peak voltage of the pulse on the pulse transformer primary windings is -260V, and the magnetron cathode voltage is -3.6 kV. On short ranges, the pulse length is 0.12 μ sec. On longer ranges when the K201 operates, the output pulse length is 0.5 μ sec. (K201 is controlled by RANGE switches in the display unit.)

As a result:

<u>Range</u>	<u>Pulse Length</u>	<u>Pulse Repetition Frequencies</u>
0.25 nm	0.12 μ sec	920 Hz
0.5 nm	0.12 μ sec	920 Hz
1 nm	0.12 μ sec	920 Hz
2 nm	0.12 μ sec	920 Hz
4 nm	0.5 μ sec	920 Hz
8 nm	0.5 μ sec	920 Hz
12 nm	0.5 μ sec	920 Hz

2) Magnetron Transmitter

While the high voltage pulse is fed to the cathode of the magnetron, the magnetron generates high energy oscillations in the region of 9445 MHz for the duration of the input pulse.

The operating point of the magnetron is at a voltage of -3.6 kV and a current of 3A. In normal operation, magnetron current can be checked with the volt meter connected to TB101-MO and ground. The typical reading in long pulse is 12 Vdc.

3) Diode Limiter

A102 is the Passive Diode Limiter fitted between the circulator and mixer assembly. It serves as a barrier to protect the mixer diodes from high amplitude r.f. energy. Irrespective of whether or not the radar is energized.

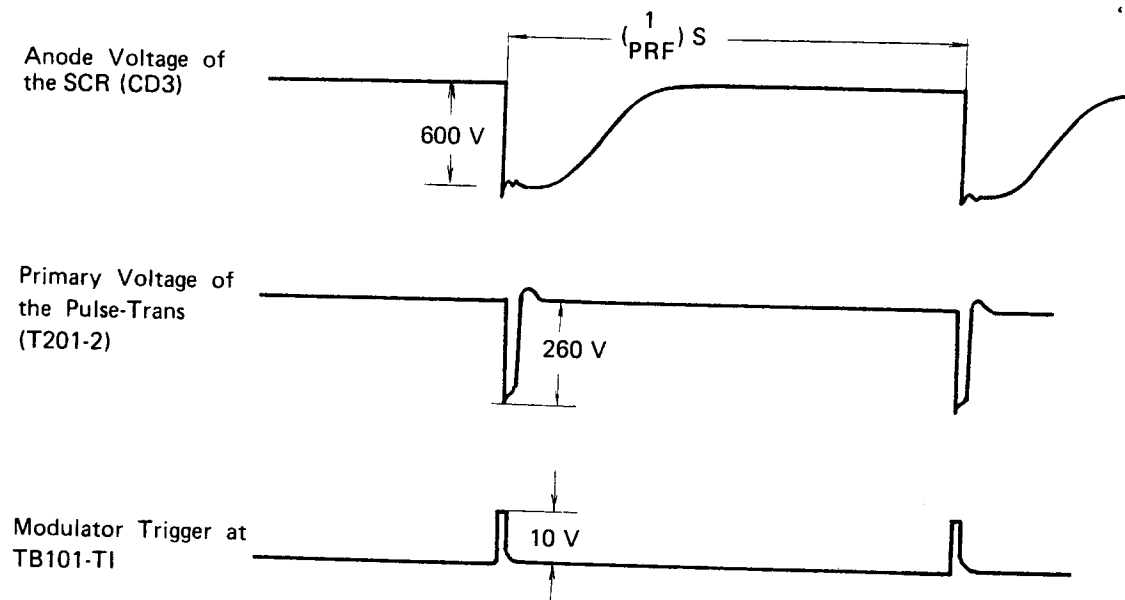

FIG. 6-4 TIME TABLE OF THE TRANSMITTER

6.2.3 Receiver

The general layout for the receiver is shown in Figure 6-5. Receiver consists of Gunn Oscillator, Attenuator, Mixer, and Receiver Printed Circuit Board.

1) Gunn Oscillator

By means of both mechanical and electrical controls, A301 is tuned to give a continuous output frequency 38 MHz higher than that of the magnetron. Mechanical tuning is achieved by the adjustment of a screw on A301; electrical tuning is achieved by the adjustment of the operator's TUNE control on the display unit.

2) Attenuator

Normally a Gunn Oscillator provides a higher output than required for efficient mixing. An attenuator is set to optimize the signal-to-noise ratio and this condition is obtained when the mixer current is 0.5 mA at either test point TP1 or TP2.

3) Mixer

The mixer is the balanced type and uses diode types 1N23E and 1N23ER. The balanced type mixer presents a good signal-to-noise ratio to the receiver system. The mixer output is resonant at 38 MHz.

4) I.F. Amplifier

The I.F. Amplifier consists of two amplifying stages. The first stage is transistor amplifier which is designed to provide a good noise figure. The noise figure of this circuit is determined by the collector current of the transistor, approximately 3.5 mA.

The second stage is the integrated circuit (IC) amplifier. This stage is controlled by the GAIN-STC circuit in the display unit. The GAIN-STC control voltage is fed to the bias terminal (3) of IC301.

GAIN-STC control voltage on TB101-GS (at STC control min) for maximum gain is approximately 5 V and for minimum gain approximately 9 V.

5) Second Detector

The second detector is an IC detector which operates as a sensitive detector amplifier. The negative going video signal appears across R13, the I.F. component is removed, and the video signal is fed to the video circuit.

6) Video Circuit

The video circuit consists of an emitter follower/video integrator. The emitter follower operates as an impedance transformer to drive the coaxial cable which feeds the video signal to the display unit.

The video integrator circuit is provided for test purposes when the Gunn Oscillator is being tuned.

The circuit is a dc restorer circuit. When the negative going video pulses are fed on CD8, the charging current flows via CD8 and C24. As a result, C24 is charged negatively to approximately -1 V dc which appears on TB101-32. Proper tuning of Gunn Oscillator is achieved when the tuning voltage on TB101-32 is at a peak value.

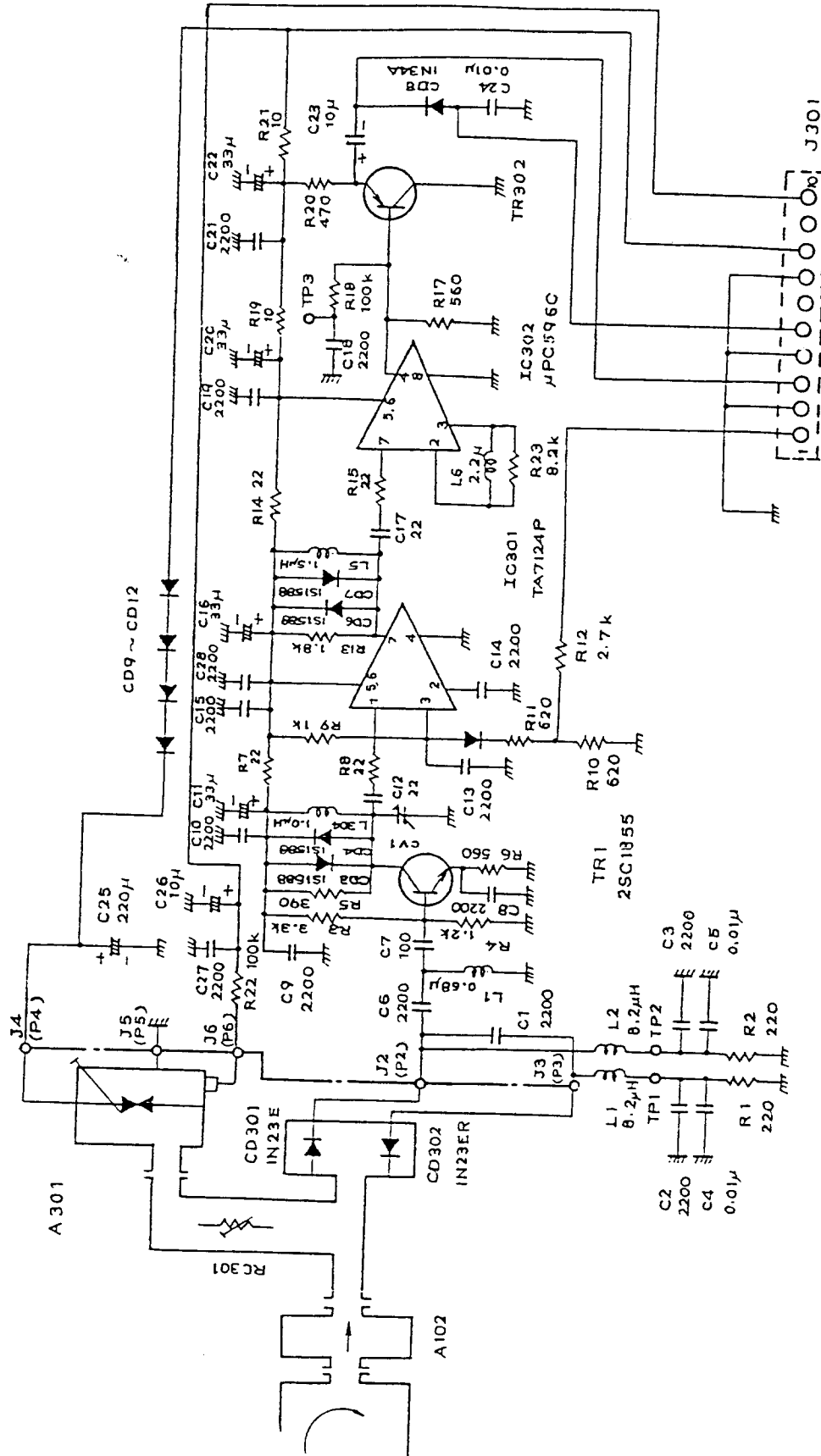

FIG. 6-5 RECEIVER UNIT

6.3 DISPLAY UNIT

6.3.1 General

Most of the display unit components are mounted on five printed circuit boards; the remaining components are chassis mounted. The display unit circuitry consists of the main control, control panel, power supply, CRT display, and CRT display video circuits.

6.3.2 Main Control Circuits

1) Video Circuit

The incoming negative going video signal is fed to the FTC (Rain-Clutter) circuit. The FTC circuit consists of a capacitor C10, a resistor R22, and a diode CD3. CD3 operates as a diode switch which is controlled by the RAIN CLUTTER switch on the display unit control panel via the Transistor TR3. In the "OFF" state of the RAIN CLUTTER switch, CD3 is conductive, and the video signal is fed to the inverting amplifier without being differentiated. In the "ON" state of the RAIN CLUTTER switch, CD3 is not conductive, and the video signal is differentiated by C10 and R22.

The negative going output of the FTC circuit is amplified by TR4 and the inverted (positive going) output signal appears on the TR4 collector. The output of the inverting amplifier is fed to the dc restorer circuit via the emitter follower TR5.

The dc restorer circuit consists of CD5 and followed by TR6. TR6 is an emitter follower and drives the tuning indicator circuit and the comparator. The positive going output signal of TR6 is fed to the integrator circuit C16 and changed into dc voltage. The dc voltage across C16 biases TR8 Base and controls the brilliance of the Tuning Indicator LED. TR7 controls the maximum brilliance of the Tuning Indicator LED which is determined by the BRIL switch setting on the front control panel.

2) Comparator

The comparator IC2 changes the analog video signal into a digital pulse train and produces the negative going pulses on IC2-7. The output of IC2 is inverted by IC14.

3) Pulse Stretch

The positive going digital video pulses are fed to the pulse stretch circuit. The pulse stretch circuit consists of eight bits shift register IC3 and NOR gates, IC4 and IC5. IC3 produces eight delayed pulses, and the delay time between pulses is controlled by the clock pulses on IC3-8.

The clock pulse frequency is selected by the transmitter pulse width signal determined by setting the RANGE switches. The clock pulse frequency is 17.5 MHz at short pulse and 4.375 MHz at long pulse. Two outputs Q1 + Q2, or five outputs (Q1 - Q5) or all of eight outputs (Q1 - Q8) are fed to the NOR gates and added to the input pulse. The stretched output pulses appear on IC5-6, IC5-12 and IC5-8 and selected by IC6. IC6 is a data selector IC and controlled by RANGE data signal (R0, R1, R2).

4) Buffer Memory

The output video pulses of the pulse stretch circuit are fed to the buffer memory (IC7). The displayed range is divided into 112 range cells. Therefore, the required

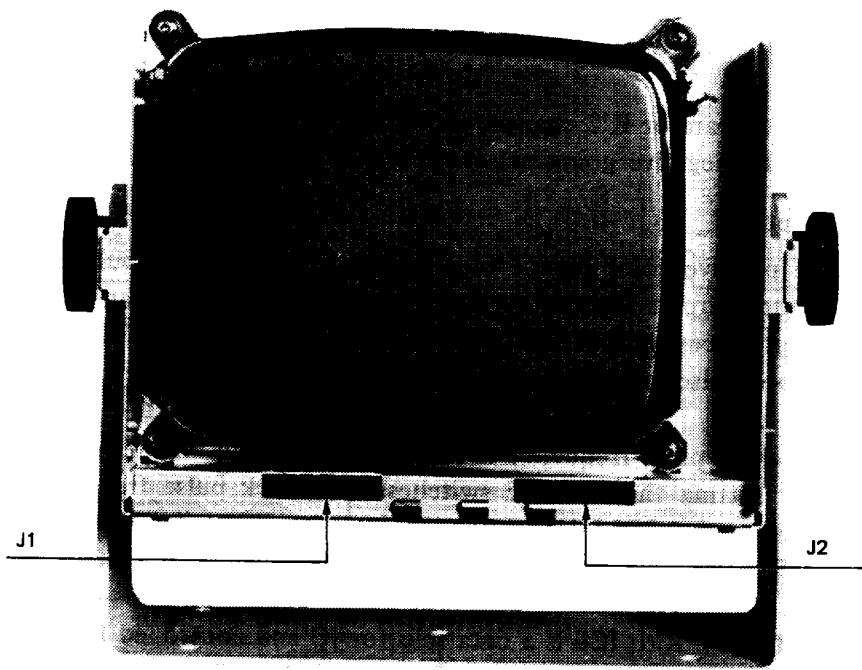
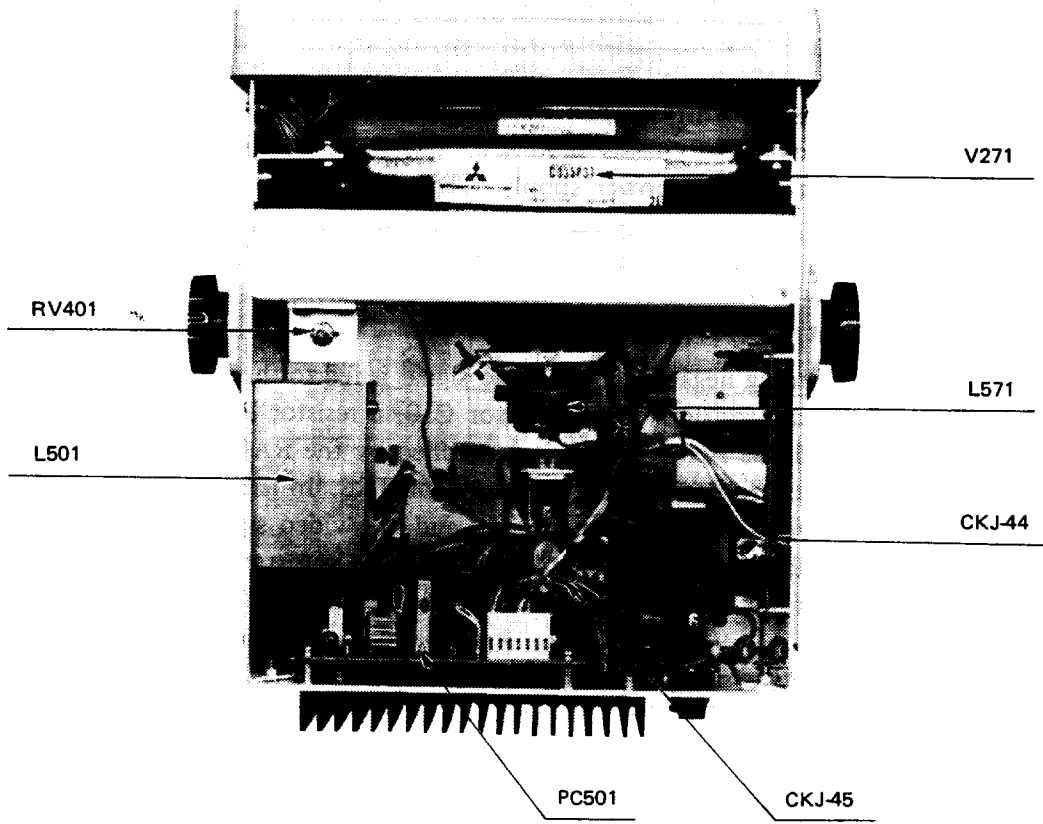

FIG. 6-6 DISPLAY UNIT - 1/2

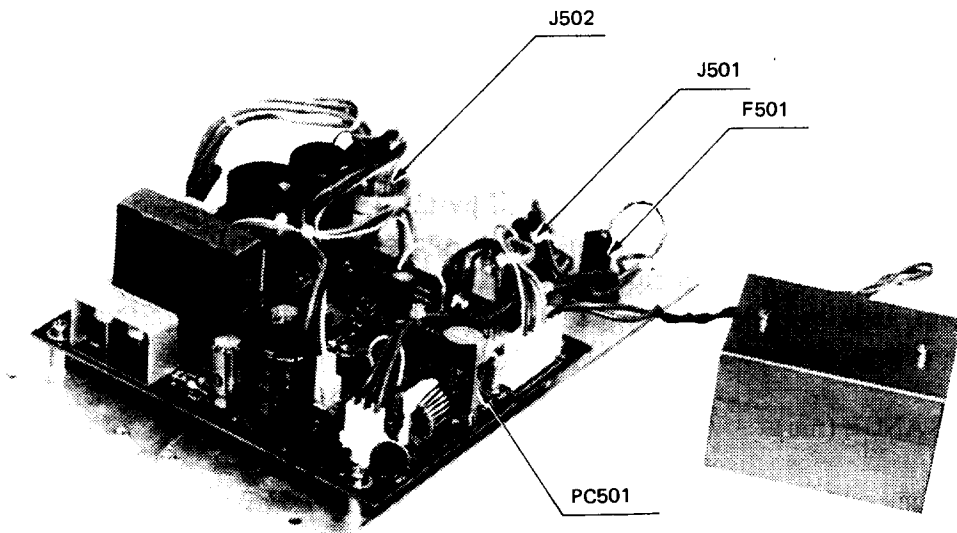
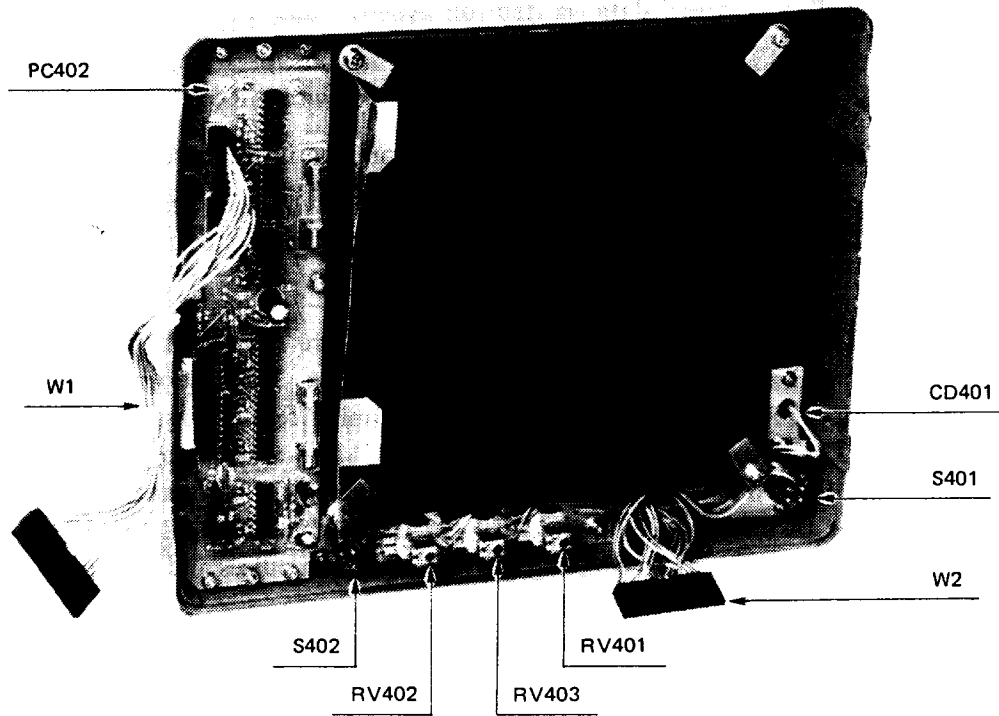

FIG. 6-6 DISPLAY UNIT - 2/2

buffer memory will be 112 bits for the video data of each transmission. Three transmissions of video data are stored in the buffer memory (IC7) for the interference rejection circuit. The video data is written into the memory by the writing pulse fed to IC7-14. The address data is fed on A0-A8 and the read data appears on D0 (IC7-7).

5) Interference Rejecter

The video data sent to the video RAM from the interference rejecter circuit is delayed by two transmissions. The video data of the last three transmissions is stored in the buffer memory IC7. This video data is read serially in each range step by A7 and A8 address control. No. 1 and No. 2 data of IC7-7 are latched on IC8 by timing control. After latching, No. 3 data is present at IC7-7. These three data are fed to NOR gate IC9-6 and added. No. 1 and No. 2 data are fed to NAND gate IC11-12, No. 2 and No. 3 data are fed to NAND gate IC11-6. The interference noise pulse which is not synchronized to the transmission timing cannot pass through IC11-12 or IC11-6. The output pulses of IC11-12 and IC11-6 are fed to NOR gate IC12-6 and added. IC10-6 output appears in the IR switch "OFF" state. IC12-6 output appears in the IR switch "ON" state. IC9-12, IC12-11, IC10-11, IC11-8, IC12-8, IC9-8, and IC13 are used for making the required latch pulses and the address control data for the buffer memory.

6) Video RAM

The output of the interference rejecter circuit is added with the marker pulse by NOR gate IC20-8 and fed to "AND" gate IC61-12. IC61-12 is the "AND" gate for writing zero to video RAM in the "STANDBY" position of the POWER switch.

The video RAM consists of four 16K (16,384) bits dynamic random access memory ICs in a parallel connection.

Video data, multiplex address data, row address strobe pulse, column address strobe pulse, and writing pulses are fed to IC65-IC68.

7) Gate Generator

The gate generator IC22 is triggered by the delay circuit IC34-8 output, and the output of IC22-9 goes to "High" state. Clear pulse from IC20-12 of the buffer memory address counter circuit is fed to IC22-13 (CR2) after 112 video data sampling samples and the output of IC22-9 returns to "0" state. The output duration of IC22-9 is varied at each range as follows:

RANGE (nm)	0.25	0.5	1	2	4	8	12
Time (μ sec)	6.4	6.4	12.8	25.6	51.2	102.4	153.6

The output of IC22-9 (Q2) is fed to the sampling clock oscillator and the other circuits. IC22-5 produces the address data selector control pulse of the interference rejecter circuit.

8) Sampling Clock OSC

The sampling clock oscillator consists of IC14-11, IC14-6 and IC14-8. The output of IC22-9 is fed to IC14-13 and controls the oscillation. When IC14-13 is 1 state, the circuit of IC14-11 and IC14-6 oscillates and produces the pulse train. The output frequency is adjusted to 17.5 MHz by CV1. The sampling clock pulse is fed to the count down circuit via the buffer inverter IC14-8.

9) Count Down

The count down circuit produces the sampling clock pulses of 1 to 12 nm range. IC15 is two 4 stage FF. One of 4 stage FF is used as four 1/2 frequency dividers and the other is used 1/3 divider with the feedback by IC76-6 and IC76-8.

10) Sampling Clock Select

The sampling clock select circuit produces the sampling clock pulse fitted on the range which is set on the RANGE switches by selection from the output of sampling clock OSC or the count down output.

The sampling clock frequency versus RANGE relation is as follows:

RANGE (nm)							
	0.25	0.5	1	2	4	8	12
Frequency (MHz)							
	17.5	17.5	8.75	4.375	2.1875	1.09375	0.72917
Period (μ sec)							
	0.057	0.057	0.114	0.229	0.457	0.914	1.371

IC17 is the clock pulse select circuit for the pulse stretch circuit IC3. IC17-6 output is 17.5 MHz at 0.25 to 2 nm range and 4.375 MHz at 4 to 12 nm range.

11) R/W Clock Select

The read/write clock select circuit selects the pulse from the sampling clock pulses and the display clock pulses by the sampling/displaying timing and the Range data. At sampling time, this circuit selects the output of the sampling clock select circuit. At the 0.25 nm range display time, this circuit selects 0.375 MHz pulse of H counter and at the other range display time, this circuit selects 0.75 MHz pulse of H counter, 0.375 MHz and 0.75 MHz pulse are gated by IC24-3 and IC24-11 and are fed to IC25 at the time of the video RAM writing only.

12) Memory Add Counter

The address counter IC18/19 produces seven bits address data for the buffer memory (IC7 AO-A6). IC20-12 produces the stop pulse after 112 pulses of the input clock pulses.

13) W Pulse Generator

The W Pulse Generator IC72 produces the writing pulses to the video RAM from the X address counter output X0 and X1. Four outputs of IC73 are added with the video RAM clear pulse by IC74 and fed to four 16K bits dynamic RAM IC65-68.

14) Parallel/Serial Converter

The four bits parallel data of the video RAM output is fed to the four bits shift resistor IC62 D4 to D1 input and latched by the mode control pulse on IC62-6. The serial video pulse appears on Q4 IC62-10 clocked by the 6 MHz clock input pulse on IC62-8/9.

15) Bearing Pulse Generator

The signal of the motor-encoder in the scanner unit is fed to the schmitt trigger IC34-11 via a filter of C25 and R51 and shaped into a suitable trigger pulse. The IC34-10 output is then fed to IC78 (monostable multivibrator) IC78-5 produces an approximately 700 μ sec pulse IC78-5 output is fed to IC35 and synchronized to the display timing. At the same time IC35 is controlled by the OPERATE signal that is the output of AND gate IC80-3. IC80-1 input is the 90 seconds timer output. IC80-2 input is OPERATE switch signal of which timing is synchronized to display vertical timing by IC79.

16) Main Trigger Generator

The IC35-6 output is fed to the main trigger generator IC21 via a differential circuit made up of C65, R78 and R79. IC21-13 produces an approximately 10 μ sec main trigger pulse which is controlled by a HOLD signal from IC80-6. The main trigger pulse stops whenever the HOLD switch is pushed, or for approximately 0.5 second during changes of the transmitter pulse width. IC41-6 and IC78-4 produce the 0.5 second pulse from the pulse width control signal when the RANGE switch is changed.

17) Transmitter Trigger Generator

The trailing edge of the pulse from IC21-13 is differentiated by C20 and R43 is amplified by TR12 and TR12-C output is fed to TR11. TR11 is an emitter follower and drives the modulator.

18) Delay Circuit (0 nm adjust)

The delay circuit consists of R46, RV3, C22 and IC34-8 and compensates for the delay time between transmitter triggering and firing by adjusting RV3 so that received video appears on the display at its proper range.

19) Gain STC (Sea Clutter) Circuit

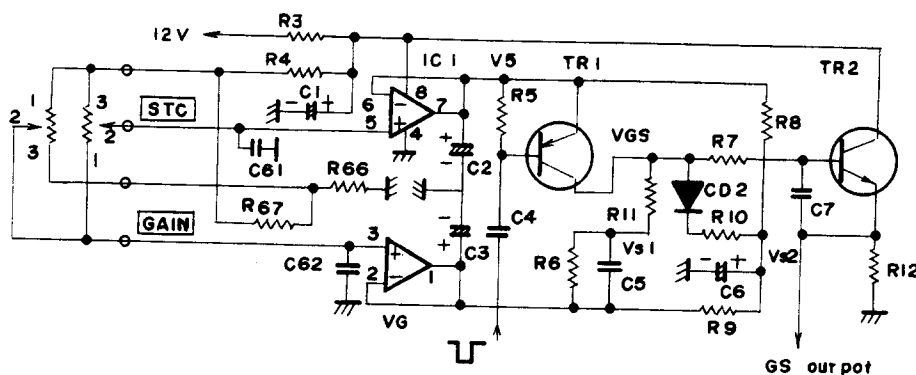

FIG. 6-7 GAIN - STC CIRCUIT

IC1-1 is a voltage follower of GAIN control, IC1-7 is a voltage follower of STC control. With the SEA CLUTTER control fully counterclockwise, V_s is equal to V_G . Consequently, the dc output voltage of GAIN control appears on TR2-E (GS output) via R6, R11, R7 and TR2. GS output voltage variation is approximately 5 V to 9 V. When GS output voltage is 5 V, the IF gain is highest.

When the Sea Clutter Control is clockwise, and the negative going pulse from the delay circuit is fed to TR1-B, TR1 turns on. Therefore, C5 will be charged up to a voltage determined by V_s , V_G and the ratio of R11 and R6. After the GS pulse is over, TR1 turns off and V_G changes from V_s to V_{s1} and C5 begins to discharge via R6, R11 and R10. When V_G reaches V_{s2} , CD2 goes into cut off, then C5 continues to discharge via R6 until V_G becomes equal to V_G . GS output is filtered in the receiver unit and fed to the IF amplifier.

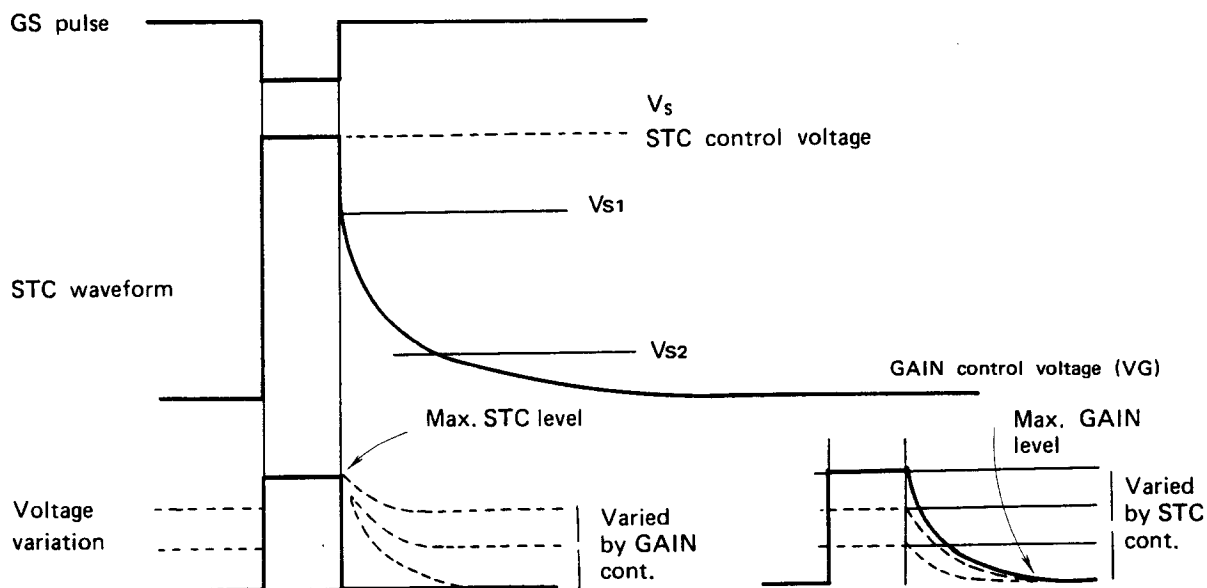

FIG. 6-8 GAIN - STC WAVEFORM

20) Clear Pulse Generator

The signal from the SHM switch is fed to IC34-3 via the R52 and C26 filter and the output pulse at IC34-4 is fed to IC34-1 and inverted. IC34-2 output is fed to IC35-12 and synchronized into the bearing pulse. IC35-8 output is fed to the bearing counter IC37-2, 12 and IC38-2, 3 via C24, R49, R50 (differential circuit) and IC34-6.

21) Bearing Counter

The bearing counters IC37 and IC38 produce 11 bits antenna position data for the RO/XY converter. QA1 output of IC37-3 is fed to the interference rejecter circuit.

22) RO/XY Converter

The RO/XY converter consists of the bearing data control IC39, IC40 the range counter IC27, IC28, IC26-8 (the function ROM), and the quadrant control circuit IC41, IC31, IC34, IC44.

The function ROM has the conversion table calculated for SIN between 0° to 90°. Bearing data for each quadrant is controlled by IC39 and IC40. In one range, step X address and Y address conversion is operated serially by the bearing data control and the quadrant control circuit. This circuit produces the pulse train and up/down control signal for X, Y address counters.

23) X Address Counter

The X address counter IC45 and 46 produce eight bits X address data for writing to the video RAM. PPI center address data are set on IC46-A, B, C, D input before count.

24) Y Address Counter

The Y address counter IC47 and 48 produce eight bits Y address data for writing to the video RAM. PPI center address data are set on IC48-A, B, C, D input before count.

25) Marker Generator

The marker generator consists of the counter IC29, 54, 27 pulse generator IC30, the data selector IC32, and the marker pulse generator IC23 and IC31-3. IC32 sets the marker position by the range data. In 0.25 or 0.5 nm range, IC29 is set 0 at every 54 range pulses and in the other ranges, IC29 is set 0 at every 27 pulses. 0 pulse of IC31-3 is fed to IC20-5 as the marker pulse. IC20-6 output is controlled by IR switch.

26) Address Data Select

The address data select circuit consists of four data selectors IC69, 70, 71, 72 and produces seven bits address data for the video RAM from X, Y address counter data and H. V. counter data by the timing of R/W and RAS/CAS.

27) Master Oscillator

The master oscillator IC49 is a crystal controlled oscillator and produces the 6 MHz master clock pulse.

28) Horizontal Counter

The horizontal counter consists of IC52, 53, 55 and IC54-11, and produces nine bits X address data at display time. IC54-11 sets the horizontal counter to 1/384 divider.

29) Vertical Counter

The vertical counter consists of IC55, 56 and IC54-3, 6 and produces nine bits Y address data at display time. IC54-3, 6 set the vertical counter to 1/26 divider.

30) Horizontal and Vertical Synchronizing Pulse Generator

IC57-14 produces the horizontal synchronizing pulse from the outputs of the horizontal counter. IC57-14 output is inverted by IC49-10 and IC49-10 output is fed to the CRT display. IC58-9 produces the vertical synchronizing pulse from the outputs of the vertical counter. IC58-9 output is inverted by IC49-8 and IC49-8 output is fed to the CRT display. IC59 produces the horizontal blanking pulse on IC59-4, the video RAM writing pulse on IC59-7, the vertical blanking pulse on IC59-9, and the SHM gate pulse on IC59-13.

31) SHM Generator

IC50, 51 produce the SHM line on the CRT screen. The SHM will be generated when the proper XY address and unblanking signals are present at the input to IC51 Pins 3 and 4.

32) 90-Second Timer

IC33-6 changes 0 to 1 after approximately 90 seconds from setting the OPERATE switch to STBY. At the same time, the READY lamp (CD401) glows.

33) SHM Mixing, Blanking Gate

The video pulse is fed to IC63-5 and the SHM pulse is fed to IC63-4. Mixed output appears on IC63-6 and is gated by the blanking gate IC64-6 and IC64-3.

34) Video Buffer

IC64-6 output pulse amplitude is controlled by IC64-8 and IC64-11 and fed to TR13 emitter follower. TR13-E output is fed to the CRT display via the intensity adjust RV4.

35) Display PCB

The display printed circuit board contains the vertical deflection circuit IC401, the horizontal deflection circuit Q501, IC401, Q502, Q503 the blanking circuit Q401, Q402 and the power supply circuit T502, D503, D506, D504.

IC401 operates as the vertical oscillator, the vertical deflection coil driver, and the horizontal oscillator. IC401-9 output is fed to the horizontal driver Q502 and Q502-C output is fed to the horizontal output Q503 via T501. Q503-C drives the horizontal deflection coil and the flyback transformer T502.

The horizontal and vertical blanking pulses are mixed and amplified by Q401 and Q402. Q402-C output is fed to the video AMP Q205-E in the video PCB.

36) Video PCB

The video amplifier Q205 and Q206 form a cascade connected amplifier to amplify the video signals of the video buffer output. Q206-C output is fed to the CRT cathode.

37) Control Panel Circuit PCB

The control panel circuit PCB contains the RANGE switch data hold circuit with LED indicators and RAIN CLUTTER, IR, BRIL, SHM MARKERS control data generator circuits with RAIN CLUTTER and IR LED's. IC1 holds the range data and drives LED indicator. IC2 changes the range data into three bits binary data. IC3 is a chattering free circuit controlled by the latching pulse of IC6-8. RAIN CLUTTER signal on IC3-5 and IR signal on IC3-7 are fed to IC4 (dual FF). IC4 output produce ON and OFF control signal alternately every input signal. BRIL signal on IC3-12 and SHM MARKERS signal on IC15 are fed to IC5 and change to two bits control data. IC6-4 and IC6-6 are used to initialize the control data.

38) Power Supply

The power supply circuit is designed to provide the various power output for the whole radar from nominal ship's mains of 12 V, 24 V or 32 V dc. The power supply circuit consists of the switching type AVR, the converter, the control circuit, and the rectifier circuits. The basic circuit of the power supply for 12V and 24/32V operation is shown in Figure 6-9.

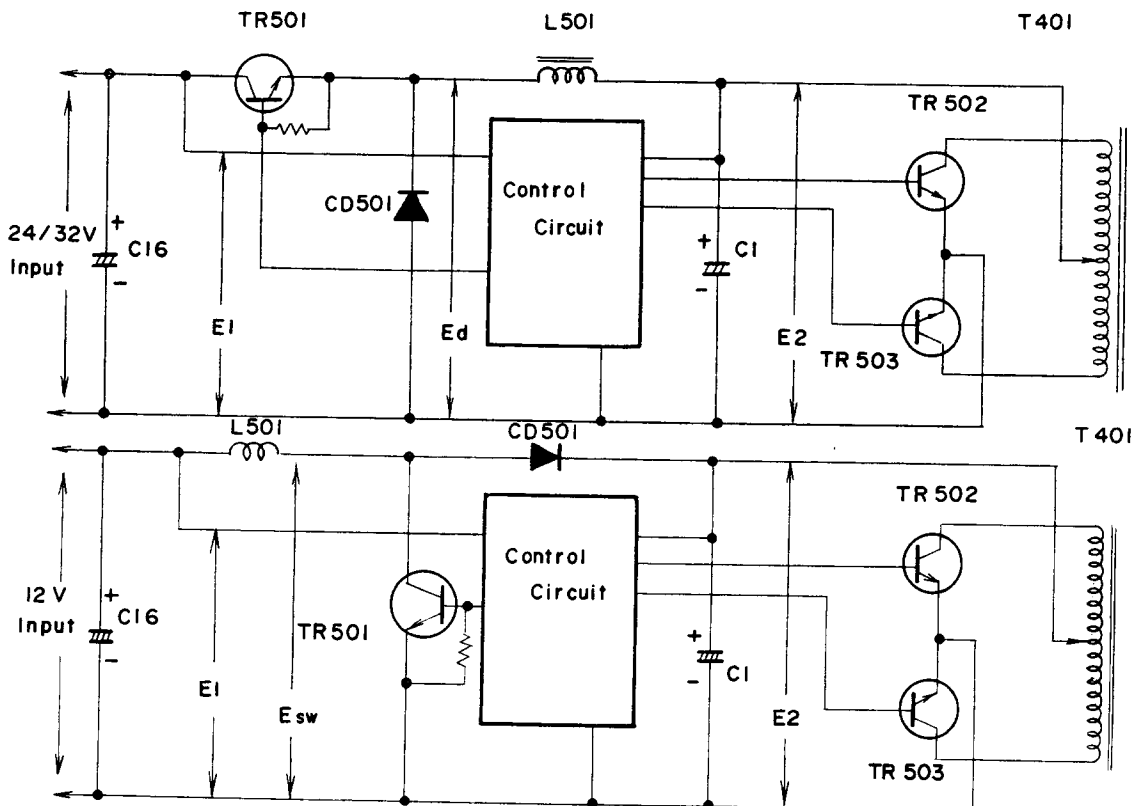

FIG. 6-9 THE BASIC CIRCUIT

(A) For Step Down Operation

While the transistor switch is ON, power is fed to the load (the converter circuit) via an inductor L501. During the OFF time, the charged energy in the inductor is continuously fed to the load via a diode CD501. If these switch, times are denoted by T_{on} and T_{off} , the voltage across the diode E_d is such as shown in Figure 6-10.

Its peak value is equal to the supply voltage E1.

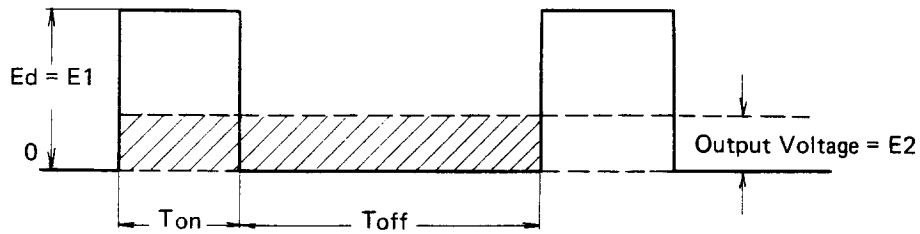

FIG. 6-10 ACROSS VOLTAGE OF THE DIODE

Therefore, the output voltage E2 is given by the average of the supply voltage. Consequently, the output voltage is described by the following equation:

$$E2 = \frac{T_{on}}{T_{on} + T_{off}} \cdot E1$$

Therefore, the output is held at a constant voltage by varying the switching time ratio according to the supply voltage.

(B) For Step Up Operation

While the transistor switch is ON, energy is sufficiently charged into the inductor. During the OFF time, the charged energy in the inductor is added on the supply voltage, and is fed to the load and capacitor C1 via diode CD501.

While the switch is ON, the capacitor continuously feeds the power to the load; therefore, the output is held to the constant voltage. Voltage across transistor switch ESW is shown in Figure 6-11. Its peak value is equal to the output voltage E2.

Therefore, the supply voltage is given by the time average of the output voltage.

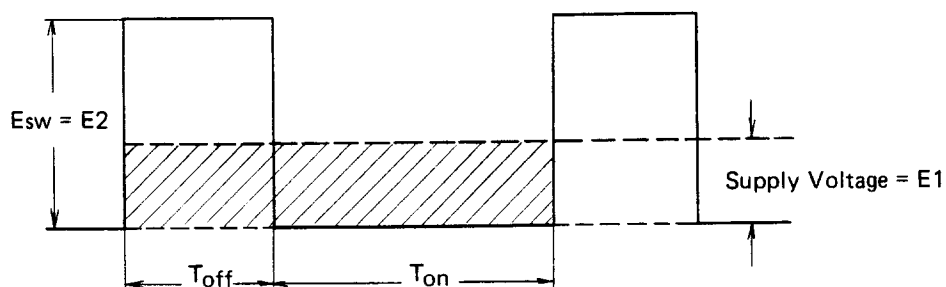

FIG. 6-11 ACROSS VOLTAGE OF THE TRANSISTOR SWITCH

Consequently, the output voltage is described in the following equation:

$$E2 = \frac{T_{on} + T_{off}}{T_{off}} \cdot E1$$

The constant output voltage is obtained by the same manner as for step down operation.

(C) Converter

TR2 and TR3 are the transistor switches, and the complementary squarewaves are fed to TR2-B and TR3-B. The 3000 Hz squarewave appears on the primary windings of T401. The secondary outputs of T401 are fed to the rectifier circuits.

(D) Control Circuit

IC2 drives the converter TR2, TR3 and AVR control TR3. The switching frequency is determined by C8 and R16. The 3000 Hz squarewave is superimposed on the reference voltage of IC1-6. This reference voltage is fed to IC1-5 and the output voltage is fed to IC1-4 via the AVR ADJ RV1. These two voltages are compared in IC1: the output pulse appears on IC1-9. This output pulse controls the transistor switch via two stage drivers. The regulated output is adjusted to 17V by RV1.

(E) Rectifier Circuits

The +330V, +12V, +5V, -5V are produced in this circuit and fed to display unit and scanner unit.

(F) HV Protection Circuit

This circuit is provided to prevent a short circuit of the power supply when the SCR (Modulator circuit) is continuously held in a conductive condition.

IC3-2 triggers on a negative-going signal when HV voltage (+330V) reaches +170V (voltage of IC3-2 reaches +4V). Once triggered, the IC3-3 is held +12V until the set time has elapsed. The duration of the set time is given by $T = 1.1 \times (R22) \times (C14)$ and is about 1 sec.. As a result, K1 is OFF and the power supply circuit and the modulator circuit are separated.

SECTION 7

PARTS LIST

7.1 ELECTRICAL PARTS LIST

7.2 MECHANICAL PARTS LOCATION LIST

1200 SCANNER UNIT TYPE M89362

MAIN CHASSIS TYPE CQC - 177

REF.	TYPE	DESCRIPTION	JRC P/N	RAYTHEON P/N
A101	H-6AJRD00001	CIRCULATOR	6AJRD00001	984929-145
A102	NJS6918	DIODE LIMITER	5EZAA00005	
C101	ECE-B1ES102	25V1000μF	5CEAA01409	
C102	ECQ-V05103JC		5CRAA00337	
M101	MPEM00133A		MPEM00133A	
MT101	SR-1 FM4.9 x 4.9 x 6		5MPAB00001	
P201	PCN6-10S-2.5C		5JDAA00154	984929-142
P301	PCN6-10S-2.5C		5JDAA00154	984929-142
PS201	PCN6-LOCK(D)		5JDAA00170	984929-231
PS301	PCN6-LOCK(D)		5JDAA00170	984929-231
PT201	PCN6-2226CF		2911101001	
PT301	PCN6-2226CF		2911101001	
R101	ERX-2ANJ4R7	2W 4.7 OHM	5REAG00049	
S101	S-116		5SAAB00002	587922-2
S102	Type; RS-1, NO		5SJAC00003	
TB1	KH4105-20P	20P	5JTDC00003	

TRANSMITTER CHASSIS TYPE CNM - 70

REF.	TYPE	DESCRIPTION	JRC P/N	RAYTHEON P/N
V201	M1315	MAGNETRON	5VMAA00023	981957-12

MODULATOR PCB ASSEMBLY (PC201) TYPE CNM - 71

REF.	TYPE	DESCRIPTION	JRC P/N	RAYTHEON P/N
C1	DD31-2B472K500V02	500V 4700PF	5CBAB00406	
C2	ECQ-V05473JC		5CRAA00336	
C3	ECE-A1CS470	16V 47μF	5CEAA01342	
C4	ECW-H6H153JC	0.015μF	5CRAA00085	981957-4
C5	ECW-H6H153JC	0.015μF	5CRAA00085	981957-4
C6	ECW-H6H153JC	0.015μF	5CRAA00085	981957-4
C7	ECQ-V05104JC	50V 0.1μF	5CRAA00334	
C8	ECE-A1CS470	16V 47μF	5CEAA01342	
C9	ECE-A1CS470	16V 47μF	5CEAA01342	
C10	ECQ-V05104JC	50V 0.1μF	5CRAA00334	
C11	DD31-2B472K500V02	500V 4700PF	5CBAB00406	
CD1	1S1832		5TXAD00173	587922-209
CD2	U05J	800V 2.5A	5TXAE00069	587922-8
CD3	S6080B		5TZAD00201	
CD4	U05J	800V 2.5A	5TXAE00069	587922-8
CD5	V06C		5TXAE00016	
CD6	1S1588		5TXAD00040	587922-55
CD7	U05J	800V 2.5A	5TXAE00069	587922-8
CD8	HVR-3H		5TXAN00056	
CDS3	HS-UC-45-24-AN-0		5ZKAF00017	

P/N

REF.	TYPE	DESCRIPTION	JRC P/N	RAYTHEON P/N
J201	PCN6-10PA-2.5DS		5JDAA00065	
K1	Type; RL, DC12V		5KLAP00004	981957-6
L1	H-6LZRD00045	CHOKE COIL	6LZRD00045	981957-7
L2	EJ00-6LCRD00010		6LCRD00010	981957-8
L3	H-6LCRD00008		6LCRD00008	981957-9
L4	H-6LCRD00018A		6LCRD00018	
PC201	H-6PCRD00534		6PCRD00534	1037139-4
R1	ERD-25PJ100	1/4W 10 OHM	5RDAA01178	
R2	ERD-25PJ102	1/4W 1K OHM	5RDAA01181	
R3	ERD-25PJ471	1/4W 470 OHM	5RDAA01155	
R4	ERG-1ANJ470	1W 47 OHM	5REAG00151	
R5	ERD-25PJ100	1/4W 10 OHM	5RDAA01178	
R6	ERX-2ANJ4R7	2W 4.7 OHM	5REAG00049	
R7	ERX-2ANJ4R7	2W 4.7 OHM	5REAG00049	
R8	ERX-2ANJ3R9		5REAG00903	
R9	ERG-2ANJ470	2W 47 OHM	5REAG00035	
T1	H-6LPRD00041A		6LPRD00041	981957-11
TR1	2SC1212AB		5TCAA00137	587922-208

RECEIVER CHASSIS TYPE CGH - 75

REF.	TYPE	DESCRIPTION	JRC P/N	RAYTHEON P/N
A301	NJS7901B	GUNN OSC.	5ENAC00018	981957-13
CD301	1N23E		5TXAJ00009	322-1001P6
CD302	1N23ER		5TXAJ00010	322-1001P7
P2	60789-2		5JWAH00086	
P3	60789-2		5JWAH00086	
P4	60789-2		5JWAH00086	
P5	60789-2		5JWAH00086	
P6	60789-2		5JWAH00086	
RC301	H-6ATRD00005A		6ATRD00005	981957-90

RECEIVER PCB ASSEMBLY (PC301) TYPE CAE - 160

REF.	TYPE	DESCRIPTION	JRC P/N	RAYTHEON P/N
C1	DD106B222K50V02	50V 2200PF	5CBAB00303	1033012-93
C2	DD106B222K50V02	50V 2200PF	5CBAB00303	1033012-93
C3	DD106B222K50V02	50V 2200PF	5CBAB00303	1033012-93
C4	ECQ-V05103JC		5CRAA00337	
C5	ECQ-V05103JC		5CRAA00337	
C6	DD106B222K50V02	50V 2200PF	5CBAB00303	1033012-93
C7	DD105SL101J50V02	50V 100PF	5CAAA01101	
C8	DD106B222K50V02	50V 2200PF	5CBAB00303	1033012-93
C9	DD106B222K50V02	50V 2200PF	5CBAB00303	1033012-93
C10	DD106B222K50V02	50V 2200PF	5CBAB00303	1033012-93
C11	ECE-A1CS330	16V 33 μ F	5CEAA01340	
C12	DD104SL220J50V02	50V 22PF	5CAAA01093	
C13	DD106B222K50V02	50V 2200PF	5CBAB00303	1033012-93
C14	DD106B222K50V02	50V 2200PF	5CBAB00303	1033012-93
C15	DD106B222K50V02	50V 2200PF	5CBAB00303	1033012-93

REF.	TYPE	DESCRIPTION	JRC P/N	RAYTHEON P/N	REF.
C16	ECE-A1CS330	16V 33 μ F	5CEAA01340		R20
C17	DD104SL220J50V02	50V 22PF	5CAAA01093		R21
C18	DD106B222K50V02	50V 2200PF	5CBAB00303	1033012-93	R22
C19	DD106B222K50V02	50V 2200PF	5CBAB00303	1033012-93	R23
C20	ECE-A1CS330	16V 33 μ F	5CEAA01340		TP1
C21	DD106B222K50V02	50V 2200PF	5CBAB00303	1033012-93	TP2
C22	ECE-A1CS330	16V 33 μ F	5CEAA01340		TP3
C23	ECE-A1ES100	25V 10 μ F	5CEAA01348		TR1
C24	ECQ-V05103JC		5CRAA00337		TR2
C25	ECE-A1CS221	16V 220 μ F	5CEAA01338		
C26	ECE-A1ES100	25V 10 μ F	5CEAA01348		
C27	DD106B222K50V02	50V 2200PF	5CBAB00303	1033012-93	
C28	DD106B222K50V02	50V 2200PF	5CBAB00303	1033012-93	
CD3	1S1588		5TXAD00040	587922-55	
CD4	1S1588		5TXAD00040	587922-55	
CD5	1S1588		5TXAD00040	587922-55	
CD6	1S1588		5TXAD00040	587922-55	
CD7	1S1588		5TXAD00040	587922-55	
CD8	1K34A		5TXCH00001		
CD9	V06C		5TXAE00016	588114-31	
CD10	V06C		5TXAE00016	588114-31	
CD11	V06C		5TXAE00016	588114-31	
CD12	V06C		5TXAE00016	588114-31	
CV1	ECV-1ZW20X53N	MAX 20PF	5CVAC00006	981957-244	
IC1	TA7124P		5DAAD00036	981957-14	
IC2	UPC596C		5DAAA00041	981957-15	
J2	171255-1		BRTE00046	981957-232	
J3	171255-1		BRTE00046	981957-232	
J4	171255-1		BRTE00046	981957-232	
J5	171255-1		BRTE00046	981957-232	
J6	171255-1		BRTE00046	981957-232	
J301	PCN6-10PA-2.5DS		5JDAA00065		
L1	LF4-8R2K	8.2 μ H	5LCAB00032	981957-228	
L2	LF4-8R2K	8.2 μ H	5LCAB00032	981957-228	
L3	SP0408-R68K	0.68 μ H	5LCAC00174	984929-260	
L4	SP0406-1R0K	1.0 μ H	5LCAC00173		
L5	SP0406-1R5K	1.5 μ H	5LCAC00156		
L6	SP0406-2R2K	2.2 μ H	5LCAC00154	984929-142	
PC301	H-6PCRD00533		6PCRD00533	1037139-5	
R1	ERD-25PJ221	1/4W 220 OHM	5RDAA01182		
R2	ERD-25PJ221	1/4W 220 OHM	5RDAA01182		
R3	ERD-25PJ332	1/4W 3.3K OHM	5RDAA01168		
R4	ERD-25PJ122	1/4W 1.2K OHM	5RDAA01142		
R5	ERD-25PJ391	1/4W 390 OHM	5RDAA01239		
R6	ERD-25PJ561	1/4W 560 OHM	5RDAA01240		
R7	ERD-25PJ220	1/4W 22 OHM	5RDAA01217		
R8	ERD-25PJ220	1/4W 22 OHM	5RDAA01217		
R9	ERD-25PJ102	1/4W 1K OHM	5RDAA01181		
R10	ERD-25PJ621	1/4W 620 OHM	5RDAA01241		
R11	ERD-25PJ621	1/4W 620 OHM	5RDAA01241		
R12	ERD-25PJ272	1/4W 2.7K OHM	5RDAA01171		
R13	ERD-25PJ182	1/4W 1.8K OHM	5RDAA01163		
R14	ERD-25PJ220	1/4W 22 OHM	5RDAA01217		
R15	ERD-25PJ220	1/4W 22 OHM	5RDAA01217		
R17	ERD-25PJ561	1/4W 560 OHM	5RDAA01240		
R18	ERD-25PJ104	1/4W 100K OHM	5RDAA01162		
R19	ERD-25PJ100	1/4W 10 OHM	5RDAA01178		

N

REF.	TYPE	DESCRIPTION	JRC P/N	RAYTHEON P/N
R20	ERD-25PJ471	1/4W 470 OHM	5RDAA01155	
R21	ERD-25PJ100	1/4W 10 OHM	5RDAA01178	
R22	ERD-25PJ104	1/4W 100K OHM	5RDAA01162	
R23	ERD-25PJ822	1/4W 8.2K OHM	5RDAA01149	
TP1	171255-1		BRTE00046	981957-232
TP2	171255-1		BRTE00046	981957-232
TP3	171255-1		BRTE00046	981957-232
TR1	2SC1855		5TCAA00134	984929-35
TR2	2SA1015-Y		5TAAG00070	1034286-88

1200 DISPLAY UNIT TYPE M89361

MAIN CHASSIS TYPE CML - 139

REF.	TYPE	DESCRIPTION	JRC P/N	RAYTHEON P/N
P404	172142-6	6P	5JWAH00448	
P405	172142-6	6P	5JWAH00448	
P411	60789-2		5JWAH00086	
P412	60789-2		5JWAH00086	
P505	172142-6	6P	5JWAH00448	
PT404	170369-1		5JWAH00438	
PT405	170369-1		5JWAH00438	
PT505	170369-1		5JWAH00438	
RV401	RPF10SA15S200 OHM KK	10W 200 OHM	5RPAB00206	
W1	H-6ZCRD00086		6ZCRD00086	
WZ1	H-6WZRD00002	DT-0902XU	6WZRD00002	

MAIN CONTROL PCB (PC401) ASSEMBLY TYPE CMC - 259

REF.	TYPE	DESCRIPTION	JRC P/N	RAYTHEON P/N
C1	ECE-A1CS330	16V 33 μ F	5CEAA01340	
C2	ECE-A1CS330	16V 33 μ F	5CEAA01340	
C3	ECE-A1CS330	16V 33 μ F	5CEAA01340	
C4	ECE-A1HS010	50V 1 μ F	5CEAA01366	
C5	ECQ-V05103JC		5CRAA00337	
C6	ECE-A1CS330	16V 33 μ F	5CEAA01340	
C7	DD107SL221J50V02	50V 220PF	5CAAA01105	
C9	ECE-A1ES100	25V 10 μ F	5CEAA01348	
C10	DD107SL331J50V02	50V 330PF	5CAAA01106	
C11	ECE-A1CS330	16V 33 μ F	5CEAA01340	
C12	ECE-A1HS010	50V 1 μ F	5CEAA01366	
C13	ECE-A1CN100S	16V 10 μ F	5CEAA01243	
C14	ECE-A1CS330	16V 33 μ F	5CEAA01340	
C15	ECE-A1CS330	16V 33 μ F	5CEAA01340	
C16	FK20Y5V1H104Z		5CBAE00157	
C17	DD106SL151J50V02	50V 150PF	5CAAA01103	
C18	DD106SL151J50V02	50V 150PF	5CAAA01103	
C19	ECE-A1CS330	16V 33 μ F	5CEAA01340	
C20	501N5002 102K1	50V 0.001 μ F	5CRAC00003	984929-157
C21	501N5002 102K1	50V 0.001 μ F	5CRAC00003	984929-157
C22	DD104B221K50V02	50V 220PF	5CBAB00401	
C23	ECQ-V05104JC	50V 0.1 μ F	5CRAA00334	
C24	DD107SL221J50V02	50V 220PF	5CAAA01105	
C25	ECQ-V05683JC		5CRAA00338	
C26	ECQ-V05333JC		5CRAA00339	
C27	501N5002 222K1	50V 0.0022 μ F	5CRAC00005	984929-180
C28	501N5002 332K1	50V 0.0033 μ F	5CRAC00006	984929-212
C29	DD105SL101J50V02	50V 100PF	5CAAA01101	1033012-101
C30	ECE-A1CS330	16V 33 μ F	5CEAA01340	
C31	FK20Y5V1H104Z		5CBAE00157	
C32	ECE-A1CS101	16V 100 μ F	5CEAA01335	
C33	221M3502225M5	35WV 2.2 μ F	5CSAC00644	
C34	FK20Y5V1H104Z		5CBAE00157	
C35	FK20Y5V1H104Z		5CBAE00157	

REF.	TYPE	DESCRIPTION	JRC P/N	RAYTHEON P/N
C36	FK20Y5V1H104Z		5CBAE00157	
C37	FK20Y5V1H104Z		5CBAE00157	
C39	FK20Y5V1H104Z		5CBAE00157	
C40	FK20Y5V1H104Z		5CBAE00157	
C41	FK20Y5V1H104Z		5CBAE00157	
C42	FK20Y5V1H104Z		5CBAE00157	
C43	FK20Y5V1H104Z		5CBAE00157	
C44	FK20Y5V1H104Z		5CBAE00157	
C45	FK20Y5V1H104Z		5CBAE00157	
C46	FK20Y5V1H104Z		5CBAE00157	
C47	FK20Y5V1H104Z		5CBAE00157	
C48	FK20Y5V1H104Z		5CBAE00157	
C49	FK20Y5V1H104Z		5CBAE00157	
C50	FK20Y5V1H104Z		5CBAE00157	
C51	FK20Y5V1H104Z		5CBAE00157	
C52	FK20Y5V1H104Z		5CBAE00157	
C53	FK20Y5V1H104Z		5CBAE00157	
C54	DD105SL101 J50V02	50V 100PF	5CAAA01101	1033012-101
C55	ECE-A1CS101	16V 100μF	5CEAA01335	
C56	ECQ-V05103JC		5CRAA00337	
C57	ECQ-V05103JC		5CRAA00337	
C58	501N5002 472K1	50V 0.0047μF	5CRAC00007	
C59	ECQ-V05223JC		5CRAA00335	
C60	ECE-A1ES100	25V 10μF	5CEAA01348	
C61	501N5002 332K1	50V 0.0033μF	5CRAC00006	984929-212
C62	501N5002 332K1	50V 0.0033μF	5CRAC00006	984929-212
C63	ECQ-V05103JC		5CRAA00337	
C64	FK20Y5V1H104Z		5CBAE00157	
C65	501N5002 102K1	50V 0.001μF	5CRAC00003	
CD2	1N60		5TXAF00026	1032698-197
CD3	1S1588		5TXAD00040	587922-55
CD4	1S1588		5TXAD00040	587922-55
CD5	1S1588		5TXAD00040	587922-55
CD6	1S1588		5TXAD00040	587922-55
CD7	1S1588		5TXAD00040	587922-55
CD8	1N60		5TXAF00026	1032698-197
CD9	TLR102A		5TZAD00170	984929-23
CD10	1S1588		5TXAD00040	587922-55
CV1	ECR-HA050G12		5CVAC00076	
IC1	NJM4558D		5DAAF00027	
IC2	UPC71D		5DAAA00135	
IC3	HD74LS164P		5DDAF00352	
IC4	HD74LS27P		5DDAF00401	1057704-1
IC5	HD74LS10P		5DDAF00288	167683-1
IC6	HD74LS151P		5DDAF00306	981088-1
IC7	D2115H-4		5DDAK00232	
IC8	HD74LS74AP		5DDAF00407	167684-1
IC9	HD74LS27P		5DDAF00401	1057704-1
IC10	HD74LS32P		5DDAF00298	
IC11	HD74LS10P		5DDAF00288	167683-1
IC12	HD74LS08P		5DDAF00277	157708-1
IC13	HD74LS157P		5DDAF00396	
IC14	HD74S00		5DDAF00228	
IC15	SN74LS393N		5DDAL00231	
IC16	HD74LS151P		5DDAF00306	981088-1
IC17	HD74LS00P		5DDAF00279	166046-1
IC18	HD74LS161P		5DDAF00353	165893-1

REF.	TYPE	DESCRIPTION	JRC P/N	RAYTHEON P/N
IC19	HD74LS161P		5DDAF00353	165893-1
IC20	HD74LS10P		5DDAF00288	167683-1
IC21	HD74LS123P		5DDAF00354	1057701-1
IC22	HD74LS74AP		5DDAF00407	167684-1
IC23	HD74LS27P		5DDAF00401	1057704-1
IC24	HD74LS08P		5DDAF00277	157708-1
IC25	HD74LS153P		5DDAF00307	
IC26	HD74LS10P		5DDAF00288	167683-1
IC27	HD74LS161P		5DDAF00353	165893-1
IC28	HD74LS161P		5DDAF00353	165893-1
IC29	SN74LS393N		5DDAL00231	
IC30	HD74LS20P		5DDAF00286	
IC31	HD74LS08P		5DDAF00277	157708-1
IC32	HD74LS151P		5DDAF00306	981088-1
IC33	TA7326P		5DAAD00071	
IC34	HD74LS14P		5DDAF00294	1057706-1
IC35	HD74LS74AP		5DDAF00407	167684-1
IC36	HD74LS74AP		5DDAF00407	167684-1
IC37	SN74LS393N		5DDAL00231	
IC38	SN74LS93N		5DDAL00173	167685-1
IC39	HD74LS86P		5DDAF00282	
IC40	HD74LS86P		5DDAF00282	
IC41	HD74LS86P		5DDAF00282	
IC42	H-6DLRD00004		6DLRD00004	
IC43	HD74LS151P		5DDAF00306	981088-1
IC44	HD74LS11P		5DDAF00292	1057707-1
IC45	HD74LS191P		5DDAF00417	
IC46	HD74LS191P		5DDAF00417	
IC47	HD74LS191P		5DDAF00417	
IC48	HD74LS191P		5DDAF00417	
IC49	HD74LS04P		5DDAF00278	167682-1
IC50	HD74LS02P		5DDAF00289	1033924-1
IC51	HD74LS11P		5DDAF00292	1057707-1
IC52	HD74LS161P		5DDAF00353	165893-1
IC53	HD74LS161P		5DDAF00353	165893-1
IC54	HD74LS00P		5DDAF00279	166046-1
IC55	HD74LS107P		5DDAF00280	
IC56	SN74LS393N		5DDAL00231	
IC57	HD74LS138P		5DDAF00409	981084-1
IC58	HD74LS138P		5DDAF00409	981084-1
IC59	HD74LS279P		5DDAF00412	
IC60	HD74LS10P		5DDAF00288	167683-1
IC61	HD74LS11P		5DDAF00292	1057707-1
IC62	HD74LS95BP		5DDAF00493	
IC63	HD74LS32P		5DDAF00298	
IC64	HD74LS09P		5DDAF00391	
IC65	UPD416C-2		5DDAC00118	
IC66	UPD416C-2		5DDAC00118	
IC67	UPD416C-2		5DDAC00118	
IC68	UPD416C-2		5DDAC00118	
IC69	HD74LS153P		5DDAF00307	
IC70	HD74LS153P		5DDAF00307	
IC71	HD74LS153P		5DDAF00307	
IC72	HD74LS153P		5DDAF00307	
IC73	HD74LS139P		5DDAF00305	981083-1
IC74	HD74LS08P		5DDAF00277	157708-1
IC75	HD74LS00P		5DDAF00279	166046-1

N

REF.	TYPE	DESCRIPTION	JRC P/N	RAYTHEON P/N
IC76	HD74LS00P		5DDAF00279	166046-1
IC77	HD74LS04P		5DDAF00278	167682-1
IC78	HD74LS123P		5DDAF00354	1057701-1
IC79	HD74LS74AP		5DDAF00407	167684-1
IC80	HD74LS08P		5DDAF00277	157708-1
J1	FKP-15ML		5JFAE00006	
J2	FKP-15ML		5JFAE00006	
J3	1-171825-2		5JWAH00345	
J4	171825-6		5JWAH00268	
J5	171825-6		5JWAH00268	
J6	FFC-5AMEP		5JTCA00048	
J7	171825-8		5JWAH00126	
L1	LF1-100K	10μH	5LCAB00001	
P6	DIC130		5JJAA00035	
PC401	H-6PCRD00540C		6PCRD00540	
R1	ERD-25PJ472	1/4W 4.7K OHM	5RDAA01183	
R2	ERD-25PJ102	1/4W 1K OHM	5RDAA01181	
R3	ERD-25PJ100	1/4W 10 OHM	5RDAA01178	
R4	ERD-25PJ361	1/4W 360 OHM	5RDAA01238	
R5	ERD-25PJ473	1/4W 47K OHM	5RDAA01153	
R6	ERD-25PJ222	1/4W 2.2K OHM	5RDAA01172	
R7	ERD-25PJ470	1/4W 47 OHM	5RDAA01179	
R8	ERD-25PJ471	1/4W 470 OHM	5RDAA01155	
R9	ERD-25PJ331	1/4W 330 OHM	5RDAA01151	
R10	ERD-25PJ221	1/4W 220 OHM	5RDAA01182	
R11	ERD-25PJ680	1/4W 68 OHM	5RDAA01227	
R12	ERD-25PJ102	1/4W 1K OHM	5RDAA01181	
R13	ERD-25PJ222	1/4W 2.2K OHM	5RDAA01172	
R14	ERD-25PJ103	1/4W 10K OHM	5RDAA01146	
R15	ERD-25PJ101	1/4W 100 OHM	5RDAA01175	
R16	ERD-25PJ102	1/4W 1K OHM	5RDAA01181	
R17	ERD-25PJ102	1/4W 1K OHM	5RDAA01181	
R18	ERD-25PJ332	1/4W 3.3K OHM	5RDAA01168	
R19	ERD-25PJ102	1/4W 1K OHM	5RDAA01181	
R20	ERD-25PJ560	1/4W 56 OHM	5RDAA01225	
R21	ERD-25PJ152	1/4W 1.5K OHM	5RDAA01160	
R22	ERD-25PJ222	1/4W 2.2K OHM	5RDAA01172	
R23	ERD-25PJ222	1/4W 2.2K OHM	5RDAA01172	
R24	ERD-25PJ333	1/4W 33K OHM	5RDAA01180	
R25	ERD-25PJ103	1/4W 10K OHM	5RDAA01146	
R26	ERD-25PJ681	1/4W 680 OHM	5RDAA01242	
R27	ERD-25PJ331	1/4W 330 OHM	5RDAA01151	
R28	ERD-25PJ471	1/4W 470 OHM	5RDAA01155	
R29	ERD-25PJ470	1/4W 47 OHM	5RDAA01179	
R30	ERD-25PJ473	1/4W 47K OHM	5RDAA01153	
R31	ERD-25PJ223	1/4W 22K OHM	5RDAA01147	
R32	ERD-25PJ470	1/4W 47 OHM	5RDAA01179	
R33	ERD-25PJ221	1/4W 220 OHM	5RDAA01182	
R34	ERD-25PJ101	1/4W 100 OHM	5RDAA01175	
R35	ERD-25PJ222	1/4W 2.2K OHM	5RDAA01172	
R36	ERD-25PJ471	1/4W 470 OHM	5RDAA01155	
R37	ERD-25PJ331	1/4W 330 OHM	5RDAA01151	
R38	ERD-25PJ331	1/4W 330 OHM	5RDAA01151	
R39	ERD-25PJ103	1/4W 10K OHM	5RDAA01146	
R40	ERD-25PJ101	1/4W 100 OHM	5RDAA01175	
R41	ERD-25PJ102	1/4W 1K OHM	5RDAA01181	
R42	ERD-25PJ102	1/4W 1K OHM	5RDAA01181	

REF.	TYPE	DESCRIPTION	JRC P/N	RAYTHEON P/N
R43	ERD-25PJ472	1/4W 4.7K OHM	5RDAA01183	
R44	ERD-25PJ102	1/4W 1K OHM	5RDAA01181	
R45	ERD-25PJ223	1/4W 22K OHM	5RDAA01147	
R46	ERD-25PJ221	1/4W 220 OHM	5RDAA01182	
R47	ERD-25PJ474	1/4W 470K OHM	5RDAA01187	
R48	ERD-25PJ471	1/4W 470 OHM	5RDAA01155	
R49	ERD-25PJ222	1/4W 2.2K OHM	5RDAA01172	
R50	ERD-25PJ332	1/4W 3.3K OHM	5RDAA01168	
R51	ERD-25PJ102	1/4W 1K OHM	5RDAA01181	
R52	ERD-25PJ102	1/4W 1K OHM	5RDAA01181	
R53	ERD-25PJ102	1/4W 1K OHM	5RDAA01181	
R54	ERD-25PJ332	1/4W 3.3K OHM	5RDAA01168	
R55	ERD-25PJ332	1/4W 3.3K OHM	5RDAA01168	
R56	ERD-25PJ222	1/4W 2.2K OHM	5RDAA01172	
R57	ERD-25PJ472	1/4W 4.7K OHM	5RDAA01183	
R58	ERD-25PJ102	1/4W 1K OHM	5RDAA01181	
R59	ERD-25PJ470	1/4W 47 OHM	5RDAA01179	
R60	ERD-25PJ471	1/4W 470 OHM	5RDAA01155	
R61	ERD-25PJ471	1/4W 470 OHM	5RDAA01155	
R62	ERD-25PJ102	1/4W 1K OHM	5RDAA01181	
R63	ERD-25PJ102	1/4W 1K OHM	5RDAA01181	
R64	ERD-25PJ472	1/4W 4.7K OHM	5RDAA01183	
R65	ERD-25PJ471	1/4W 470 OHM	5RDAA01155	
R66	ERD-25PJ112	1/4W 1.1K OHM	5RDAA01170	
R67	ERD-25PJ102	1/4W 1K OHM	5RDAA01181	
R68	ERD-25PJ102	1/4W 1K OHM	5RDAA01181	
R69	ERD-25PJ152	1/4W 1.5K OHM	5RDAA01160	
R70	ERD-25PJ102	1/4W 1K OHM	5RDAA01181	
R71	ERD-25PJ470	1/4W 47 OHM	5RDAA01179	
R72	ERD-25PJ100	1/4W 10 OHM	5RDAA01178	
R73	ERD-25PJ471	1/4W 470 OHM	5RDAA01155	
R74	ERD-25PJ471	1/4W 470 OHM	5RDAA01155	
R75	ERD-25PJ471	1/4W 470 OHM	5RDAA01155	
R76	ERD-25PJ683	1/4W 68K OHM	5RDAA01265	
R77	ERD-25PJ104	1/4W 100K OHM	5RDAA01162	
R78	ERD-25PJ222	1/4W 2.2K OHM	5RDAA01172	
R79	ERD-25PJ332	1/4W 3.3K OHM	5RDAA01168	
R80	ERD-25PJ470	1/4W 47 OHM	5RDAA01179	
R81	ERD-25PJ471	1/4W 470 OHM	5RDAA01155	
R82	ERD-25PJ470	1/4W 47 OHM	5RDAA01179	
R83	ERD-25PJ471	1/4W 470 OHM	5RDAA01155	
RV2	3321P-1-102	1K OHM	5RMAD00039	
RV3	3321P-1-102	1K OHM	5RMAD00039	
RV4	3321P-1-102	1K OHM	5RMAD00039	
RV5	3321P-1-102	1K OHM	5RMAD00039	
TR1	2SA1015-Y		5TAAG00070	
TR2	2SC1815-Y		5TCAF00219	1032698-100
TR3	2SA1015-Y		5TAAG00070	
TR4	2SC1815-Y		5TCAF00219	1032698-100
TR5	2SA1015-Y		5TAAG00070	
TR6	2SC1815-Y		5TCAF00219	1032698-100
TR7	2SC1815-Y		5TCAF00219	1032698-100
TR8	2SC1815-Y		5TCAF00219	1032698-100
TR10	2SC1815-Y		5TCAF00219	1032698-100
TR11	2SC1815-Y		5TCAF00219	1032698-100
TR12	2SC1815-Y		5TCAF00219	1032698-100

REF.	TYPE	DESCRIPTION	JRC P/N	RAYTHEON P/N
TR13	2SC1815-Y		5TCAF00219	1032698-100
TR14	2SC1815-Y		5TCAF00219	1032698-100
TR15	2SC1815-Y		5TCAF00219	1032698-100
TR16	2SC1815-Y		5TCAF00219	
TR17	2SC1815-Y		5TCAF00219	
X1	H-6XHRD00008	6000KHz	6XHRD00008	

CONTROL PANEL CHASSIS I TYPE CCK - 361

REF.	TYPE	DESCRIPTION	JRC P/N	RAYTHEON P/N
S451	H-6SWRD00001		6SWRD00001	

CONTROL PANEL CHASSIS II TYPE CCK - 363

REF.	TYPE	DESCRIPTION	JRC P/N	RAYTHEON P/N
CD401	TLR144		5TZAD00220	
CD402	TLR144		5TZAD00220	
RV401	K12130006-20KB	20K OHM	5RZBG00026	
RV402	K12130006-5KB	5K OHM	5RZBG00027	
RV403	K12130006-20KB	20K OHM	5RZBG00026	
S401	M2020-N-1K		5SAAB00370	
S402	MB-2011-8K		5SCAA00084	
W2	H-6ZCRD00087		6ZCRD00087	

CONTROL PANEL PCB (PC402) ASSEMBLY TYPE CCK - 362

REF.	TYPE	DESCRIPTION	JRC P/N	RAYTHEON P/N
C1	FK20Y5V1H104Z		5CBAE00157	
C2	FK20Y5V1H104Z		5CBAE00157	
C3	ECE-A1CS101	16V 100 μ F	5CEAA01335	
C4	ECQ-V05103JC		5CRAA00337	
C5	ECE-A1CS100	16V 10 μ F	5CEAA01334	
C6	ECE-A1CS100	16V 10 μ F	5CEAA01334	
C7	ECE-A1HS010	50V 1 μ F	5CEAA01366	
C8	ECQ-V05104JC	50V 0.1 μ F	5CRAA00334	
CD1	TLR102A		5TZAD00170	984929-23
CD2	TLR102A		5TZAD00170	984929-23
CD3	TLR102A		5TZAD00170	984929-23
CD4	TLR102A		5TZAD00170	984929-23
CD5	TLR102A		5TZAD00170	984929-23
CD6	TLR102A		5TZAD00170	984929-23
CD7	TLR102A		5TZAD00170	984929-23
CD8	TLR102A		5TZAD00170	984929-23
CD9	TLR102A		5TZAD00170	984929-23
CD10	1S1588		5TXAD00040	587922-55
CD11	1S1588		5TXAD00040	587922-55
CD12	1S1588		5TXAD00040	587922-55

REF.	TYPE	DESCRIPTION	JRC P/N	RAYTHEON P/N
IC1	SN74LS273N		5DDAL00189	
IC2	HD74LS10P		5DDAF00288	167183-1
IC3	HD74LS174P		5DDAF00285	
IC4	HD74LS107P		5DDAF00280	
IC5	SN74LS393N		5DDAL00231	
IC6	TC4069UBP		5DDAE00045	
J1	FH1-12S-2.54DS		5JWBS00099	
J2	FKP-15M	15P	5JFAE00005	
J3	171255-1		BRTE00046	981957-232
J4	171255-1		BRTE00046	981957-232
PC402	H-6PCRD00554A		6PCRD00554	
PL1	Type SF6/6, 12V0.06A		5WAAB00232	
PL2	Type SF6/6, 12V0.06A		5WAAB00232	
PLS1	TS05		5ZFBD00003	
PLS2	TS05		5ZFBD00003	
PLS3	TS05		5ZFBD00003	
PLS4	TS05		5ZFBD00003	
R1	IHR-8-103JA	10K OHM X8	5RZAB00136	
R2	IHR-4-103JA	10K OHM X4	5RZAB00133	
R3	ERD-25PJ221	1/4W 220 OHM	5RDAA01182	
R4	ERD-25PJ471	1/4W 470 OHM	5RDAA01155	
R5	ERD-25PJ102	1/4W 1K OHM	5RDAA01181	
R6	ERD-25PJ102	1/4W 1K OHM	5RDAA01181	
R7	ERD-25PJ102	1/4W 1K OHM	5RDAA01181	
R8	ERD-25PJ364	1/4W 360K OHM	5RDAA01277	
R9	ERD-25PJ332	1/4W 3.3K OHM	5RDAA01168	
R10	ERD-25PJ223	1/4W 22K OHM	5RDAA01147	
R11	ERD-25PJ223	1/4W 22K OHM	5RDAA01147	
R12	ERD-25PJ472	1/4W 4.7K OHM	5RDAA01183	
TR1	2SA1015-Y		5TAAG00070	1032698-96

POWER SUPPLY CHASSIS (+12 V dc) TYPE CMP - 161 - 1

REF.	TYPE	DESCRIPTION	JRC P/N	RAYTHEON P/N
C501	CK63YZ103PY500	500V 10000PF	5CBAD00031	984929-220
C502	402M1003 104K1	100V 0.1 μ F	5CRAC00273	
C503	402M1003 104K1	100V 0.1 μ F	5CRAC00273	
CD501	S6K20		5TXAC00101	
CDS501	AC84		5ZJAR00023	
F501	MF60NR-7A	GLASS FUSE	5ZFAD00019	
FS501	S-N1301		5ZFAE00001	981957-214
J501	206061-1	4P	5JWAH00087	
J502	JRC25RG-16P		5JCAA00222	
JT1	170246-1		5JWAH00406	
JT2	170246-1		5JWAH00406	
JT3	170246-1		5JWAH00406	
L501	H-6LWRD00034		6LWRD00034	981957-21
L502	SN-5		5MCAB00004	
L503	FT4X7-WN12		5MBAB00003	
L504	FT4X7-WN12		5MBAB00003	
L505	FT4X7-WN12		5MBAB00003	
L506	FT4X7-WN12		5MBAB00003	
L507	FT4X7-WN12		5MBAB00003	
L508	FT4X7-WN12		5MBAB00003	

1/4N

REF.	TYPE	DESCRIPTION	JRC P/N	RAYTHEON P/N
L509	FT4X7-WN12		5MBAB00003	
L510	FT4X7-WN12		5MBAB00003	
P403	1-172142-2	12P	5JWAH00453	
P501	640250-7		5JWAH00312	
P503	640250-6		5JWAH00450	
P504	640250-4		5JWAH00451	
P506	640250-3		5JWAH00452	
P511	60789-2		5JWAH00086	
P512	60789-2		5JWAH00086	
P513	60789-2		5JWAH00086	
P514	60789-2		5JWAH00086	
P515	60789-2		5JWAH00086	
P516	60789-2		5JWAH00086	
P517	60789-2		5JWAH00086	
P518	60789-2		5JWAH00086	
P519	60789-2		5JWAH00086	
P520	60789-2		5JWAH00086	
P521	60789-2		5JWAH00086	
PC502	H-6PCRD00584		6PCRD00584	
PT403	170369-1		5JWAH00458	
PT501	640706-1		5JTAN00020	
PT503	640706-1		5JTAN00020	
PT504	640706-1		5JTAN00020	
PT506	640706-1		5JTAN00020	
R501	ERD-25PJ470	1/4W 47 OHM	5RDAA01179	
TR501	2SD1148-O		5TDAE00126	
TR502	2SD633		5TDAE00053	
TR503	2SD633		5TDAE00053	
TRS502	AC84		5ZJAR00023	
TRS503	AC84		5ZJAR00023	

POWER SUPPLY PCB (PC501) TYPE CBD - 594

REF.	TYPE	DESCRIPTION	JRC P/N	RAYTHEON P/N
C1	ECE-T25R682SW		5CEAA01165	
C2	ECE-T25R682SW		5CEAA01165	
C3	ECQ-V05223JC		5CRAA00335	
C4	DD104SL100D50V02	50V 10PF	5CAAA00830	
C5	ECQ-V05473JC		5CRAA00336	
C6	DD107SL221J50V02	50V 220PF	5CAAA01105	
C7	ECE-A1HS101	50V 100μF	5CEAA01368	
C8	ECQ-V05103JC		5CRAA00337	
C9	ECE-T16R472SW	16V 4700μF	5CEAA01555	
C10	ECE-A1CS102	16V 1000μF	5CEAA01336	
C11	ECE-A1CS101	16V 100μF	5CEAA01335	
C12	ECE-A2WS4R7	450V 4.7μF	5CEAA01608	
C13	ECQ-V05104JC	50V 0.1μF	5CRAA00334	
C14	ECE-A1CS100	16V 10μF	5CEAA01334	
C15	ECQ-V05103JC		5CRAA00337	
C16	ECE-A1HS102	50V 1000μF	5CEAA01478	
C17	ECQ-V05104JC	50V 0.1μF	5CRAA00334	
C18	ECQ-V05104JC	50V 0.1μF	5CRAA00334	
C19	ECQ-V05104JC	50V 0.1μF	5CRAA00334	
C20	ECQ-V05104JC	50V 0.1μF	5CRAA00334	

REF.	TYPE	DESCRIPTION	JRC P/N	RAYTHEON P/N
C21	ECE-A1CS100	16V 10 μ F	5CEAA01334	
C22	ECQ-V05104JC	50V 0.1 μ F	5CRAA00334	
CD1	BZ-350	35V 10MA1W	5TXAF00158	
CD2	5D2C11		5TXAD00305	
CD3	5D2Z11		5TXAD00306	
CD6	V06C		5TXAE00016	588114-31
CD7	V06C		5TXAE00016	588114-31
CD8	V06C		5TXAE00016	588114-31
CD9	V06C		5TXAE00016	588114-31
CD10	1S1832		5TXAD00173	587922-209
CD11	1S1832		5TXAD00173	587922-209
CD12	V06C		5TXAE00016	588114-31
CD13	V06C		5TXAE00016	588114-31
CD14	U05C		5TXAE00034	5887922-97
IC1	HA17723G		5DAAG00019	984929-41
IC2	UPC494C		5DAAA00136	
IC3	HA17555PS		5DAAG00028	
J1	640388-7	7P	5JWAH00445	
J2	640388-7	7P	5JWAH00445	
J3	640388-6	6P	5JWAH00446	
J4	640388-4	4P	5JWAH00447	
J5	171825-6		5JWAH00268	
J6	640388-3	3P	5JWAH00442	
J7	171255-1		BRTE00046	981957-232
J8	171255-1		BRTE00046	981957-232
J9	171255-1		BRTE00046	981957-232
J10	171255-1		BRTE00046	981957-232
J11	171255-1		BRTE00046	981957-232
J12	171255-1		BRTE00046	981957-232
J13	171255-1		BRTE00046	981957-232
J14	171255-1		BRTE00046	981957-232
J15	171255-1		BRTE00046	981957-232
J16	171255-1		BRTE00046	981957-232
J17	171255-1		BRTE00046	981957-232
J18	171255-1		BRTE00046	981957-232
K1	Type; RL, DC12V		5KLAP00004	981957-6
L1	SN10-508A		5LLAA00026	
L2	SC-05-100		5LGAB00009	
P1	60789-2		5JWAH00086	
P2	60789-2		5JWAH00086	
P3	60789-2		5JWAH00086	
P4	60789-2		5JWAH00086	
P5	60789-2		5JWAH00086	
P6	60789-2		5JWAH00086	
P7	60789-2		5JWAH00086	
P8	60789-2		5JWAH00086	
PC501	H-6PCRD00544		6PCRD00544	
R1	ERD-25PJ471	1/4W 470 OHM	5RDAA01155	
R2	ERG-2ANJ332C	2W 3.3K OHM	5REAG00799	
R3	ERD-25PJ471	1/4W 470 OHM	5RDAA01155	
R4	ERD-25PJ102	1/4W 1K OHM	5RDAA01181	
R5	ERD-25PJ473	1/4W 47K OHM	5RDAA01153	
R6	ERD-25PJ222	1/4W 2.2K OHM	5RDAA01172	
R7	ERD-25PJ102	1/4W 1K OHM	5RDAA01181	
R8	ERD-25PJ471	1/4W 470 OHM	5RDAA01155	
R9	ERD-25PJ221	1/4W 220 OHM	5RDAA01182	
R10	ERD-25PJ221	1/4W 220 OHM	5RDAA01182	

REF.	TYPE	DESCRIPTION	JRC P/N	RAYTHEON P/N
R11	ERD-25PJ103	1/4W 10K OHM	5RDAA01146	
R12	ERD-25PJ103	1/4W 10K OHM	5RDAA01146	
R13	ERD-25PJ102	1/4W 1K OHM	5RDAA01181	
R14	ERG-1ANJ102C	1W 1K OHM	5REAG00800	
R15	ERG-2ANJ471C	2W 470 OHM	5REAG00089	280-1147-P61
R16	ERD-25PJ203	1/4W 20K OHM	5RDAA01257	
R17	ERG-2ANJ331C	2W 330 OHM	5REAG00044	280-1147-P55
R18	ERG-2ANJ101C	2W 100 OHM	5REAG00094	
R19	ERD-25PJ683	1/4W 68K OHM	5RDAA01265	
R20	ERD-25PJ683	1/4W 68K OHM	5RDAA01265	
R21	ERD-25PJ332	1/4W 3.3K OHM	5RDAA01168	
R22	ERD-25PJ104	1/4W 100K OHM	5RDAA01162	
R23	ERG-2ANJ100C	2W 10 OHM	5REAG00090	280-114791
R24	ERD-25PJ471	1/4W 470 OHM	5RDAA01155	
R25	ERD-25PJ471	1/4W 470 OHM	5RDAA01155	
RV1	3321N-1-501	500 OHM	5RMAD00012	
T1	H-6LTRD00110		6LTRD00110	
TR1	2SA839-0		5TAAG00046	1033012-114
TR2	2SC1212AB		5TCAA00137	587922-208
TR3	2SC1815-Y		5TCAF00219	1032689-100

INTER-UNIT CABLE TYPE CFQ - 1413

REF.	TYPE	DESCRIPTION	JRC P/N	RAYTHEON P/N
P1	206060-1	4P	5JWAH00375	
P2	JRC25PG-16S		5JCAA00265	
PL1	206062-1		5JWAH00372	
PT1	202237-2		5ZJBH00018	
PT2	202237-2		5ZJBH00018	
PT3	202237-2		5ZJBH00018	
W1	H-2695110006	1612-57	2695110006	

CRT DISPLAY ASSEMBLY TYPE H-6WZRD00002

REF.	TYPE	DESCRIPTION	JRC P/N	RAYTHEON P/N
V271	C935P31			
IC401	μPC1379C			
Q202	2SC711AG/2SC2603G			
Q205	2SC710D			
Q206	2SC22290Y			
Q401	2SC711AG/2SC2603G			
Q402	2SC1214C/2SC2274E			
Q501	2SC711AG/2SC2603G			
Q502	2SC1214C/2SC2274E			
Q503	2SD823HP			
D204	1S2076A/1S2471			
D205	S5500D/EM-1Z/ERB12-02RK			
D206	MZ-424-2A			
D207	MZ-424-2A			
D208	1S2076A/1S2471			
D402	S5500D/EM-1Z/ERB12-02RK			

REF.	TYPE	DESCRIPTION	JRC P/N	RAYTHEON P/N
D403	1S2076A/1S2471			
D501	RU-3A			
D502	RU-3A			
D503	RH-1C			
D504	TVR-1G/ES-1			
D506	RH-1C			
T502	334P10401			
L502	335P00501			
L503	333P01301			
L571	330P08402			
VR201	B-200			
VR202	B-5K			
VR203	B-4M			
VR401	B-10K			
VR402	B-500			
VR403	B-500			
VR502	B-500K			
C514	25V 7 μ , BP			

7.2 MECHANICAL PARTS LOCATION LIST

Reference to Fig. 113

Assembly Drawing of M89362 Scanner Unit

Location	Description	Symbol	JRC P/N	RAYTHEON P/N
1	Radome Assy Containing of No. 2		MPBX11642	
2	Nut, Special		MTL027485	
3	Radome		MTV002211	
4	Radiator Assy		MPAE00401	G50
5	Plate		MTB049799A	
6	Gear		MTT015965	
7	Ring, Retaining		BRTG01134	
8	Bearing		BRGK00072	
9	Plate		MTB103571	
10	Shaft		MTH003646	G50
11	Sems Screw M4 x 12 Brass		BSNC04012B	
12	Screw M4 x 35 Brass		BSNK04035B	
13	Washer, Spring M4 SUS304		BSSW04000S	
14	Washer, Plain M4 Brass		BSFW04000B	
15	Chassis		MTB106330A	
16	Chassis		MTB106331A	
17	Chassis		MTB106332A	
18	Circulater H-6AJRD00001	A101	6AJRD00001	1033012-114
19	Diode Limiter NJS6918	A102	5EZAA00005	
20	Waveguide, Connection		MTM002254	
21	Waveguide, Connection		MPAB01237	
22	Coaxial Rod		MTL023552	
23	Screw M4 x 60 Brass		BRTG01248	
24	Sems Screw M5 x 16 Brass		BSNC05016B	
25	Chassis		MTB106337A	
26	Receiver Unit Assy Consisting of		MDEM00594	
27	Cristal Diode 1N23E	CD301	5TXAJ00009	CGH-75 322-1001P6
28	Cristal Diode 1N23ER	CD302	5TXAJ00010	322-1001P7
29	Plate, Spring		MTD002186	
30	Rubber, Clamp		MTT006882	
31	Cristal Cap		MTC000606	
32	Screw, Special		MTL005890	
33	Cover		MTB112493A	
34	Plate, Threaded		MTB115068	
35	Sems Screw M3 x 8 Brass		BSNC03008B	
36	RCV PCB Assy	PC301	CAE-160	G95
37	Gunn Oscillator NJS7901B	A301	5ENAC00018	481957-13
38	Plate		MTB106339A	G
39	Modulator Unit Assy		MDMW01075	

SCANNER UNIT

Location	Description	Symbol	JRC P/N	RAYTHEON P/N
40	Chassis		MTB106333A	
41	Chassis		MTB106334	
42	Chassis		MTB106335	
43	Cover		MTB106336	
44	Modulator PCB Assy <i>693</i>	PC201 <i>M+</i>	CMN-71	<i>695</i> M1315
45	Magnetron M1315	V201	5VMAA00023	981957-12
46	Motor	M101	MPEM00133A	
47	Nut M4 Steel		BSHN04000S	
48	Plate		MTB103573A	
49	SHM Switch RS-1	S102	5SJAC00003	
50	Toggle Switch S116	S101	5SAAB00002	587022-2 <i>628</i>
51	Switch Cover		BRPK00171	984929-118
52	Terminal	TB101	5JTDK00003	
53	Screw M4 x 16 Steel		BRTG02546	
54	Screw M5 x 10 Steel		BRTG02544	
55	Packing		MTT016990A	
56	Bolt, Special		MTL027493	
57	Seal Washer		BRTG02490	
58	O-Ring		BRPK00109	
59	Magnet SR-1 FM4.9 x 4.9 x 6	MT101	5MPAB00001	

Reference to Fig. 114

Assembly Drawing of M89361 Display Unit

Location	Description	Symbol	JRC P/N	RAYTHEON P/N
1	Front Bezel	350	MPWM00676B	
2	Cover	350	MTV002214	
3	Hood Assy		MPOL00651	
	Consisting of			
4	Screw, Special		MTL027483	
5	Washer, Spring M4		BSSW04000S	
6	Base Assy		MPBC05221	
	Consisting of			
7	Rubber Plate		MTT017935	
8	Spacer		MTV002215	
9	Knob		MPHD00618	
10	Washer, Special		MTD003324A	
11	Filter		MTT017024A	
12	Cursor		MPDA01946B	
13	Cover		MTV002218A	
14	Plate, Retaining		MTD003415A	
15	Sems Screw M3 x 8 Brass		BSNC03008B	
16	Shield Paper		MTZ001978	
17	CRT with D.Y.		CCJ-55	
18	Shield Spring			
19	PCB		CKJ-45	
20	PCB		CKJ-44	
21	Washer, Special		MTD003426	
22	Sems Screw M4 x 10 Brass		BSNA04010B	
23	Plate, Retaining		MTB109453B	
24	Switch	S401	5SAAB00370	
25	Switch Cover		MTV002222A	
26	Resistor, Variable	RV401~403		
27	Switch, Push Button	S402	5SCAA00084	
28	Switch Cover		MTV002221A	
29	Knob		MPHD00984	
30	Spring, Clamp		BRSR00077	
31	Control Panel Assy		MDGW00804	
	Consisting of			
32	Panel Switch	S451	6SWRD00001	
33	Control Panel PCB Assy	PC402	CCK-362	
34	Spacer		MTT006277	
35	Sems Screw M3 x 18 Brass		BRTG02750	
36	Chassis		MPBC05185	
	Consisting of			
37	Chassis		MTB115165	
38	Chassis		MTB115166	
39	Plate, Retaining		MTB109477A	
40	Plate, Retaining		MTB109478A	

Location	Description	Symbol	JRC P/N	RAYTHEON P/N
41	Chassis		MTB109479A	
42	Plate, Retaining		MTB115057	
43	Cover		MTB115168A	
44	Chassis		MTB115040	
45	Chassis		MTB115167	
46	Cover		MTB115041A	
47	Shield Spring		MPSR01959	
48	Main Control PCB Assy	PC401	CMC-259	
49	Spacer		MTL027588	
50	Packing		MTT017921	
51	Packing		MTT017922	
52	Cover		MTB115086	
53	Cover		MTB115087	
54	Spacer		MTL027572	
55	Charging Choke Coil	L501	6LWRD0034	981957-21
56	Power Supply Unit Assy Consisting of		MDBW01250	
57	Chassis		MTB115227B	
58	Power Supply PCB Assy	PC501	MDBW01309	
59	Cover		MTB117172	
60	Spacer		MTL027634	
61	Radiator		MPTH00724A	
62	PCB	PC502		
63	Connector 206061-1	J501	5JWAH00087	
64	Connector JRC25RG-16P	J502	5JCAA00222	
65	Cover		MTD003410A	
66	Fuse Holder S-N1301	FS501	5ZF AE00001	981957-214

M89362 SCANNER UNIT
WEIGHT APPROX. 9.5 kg

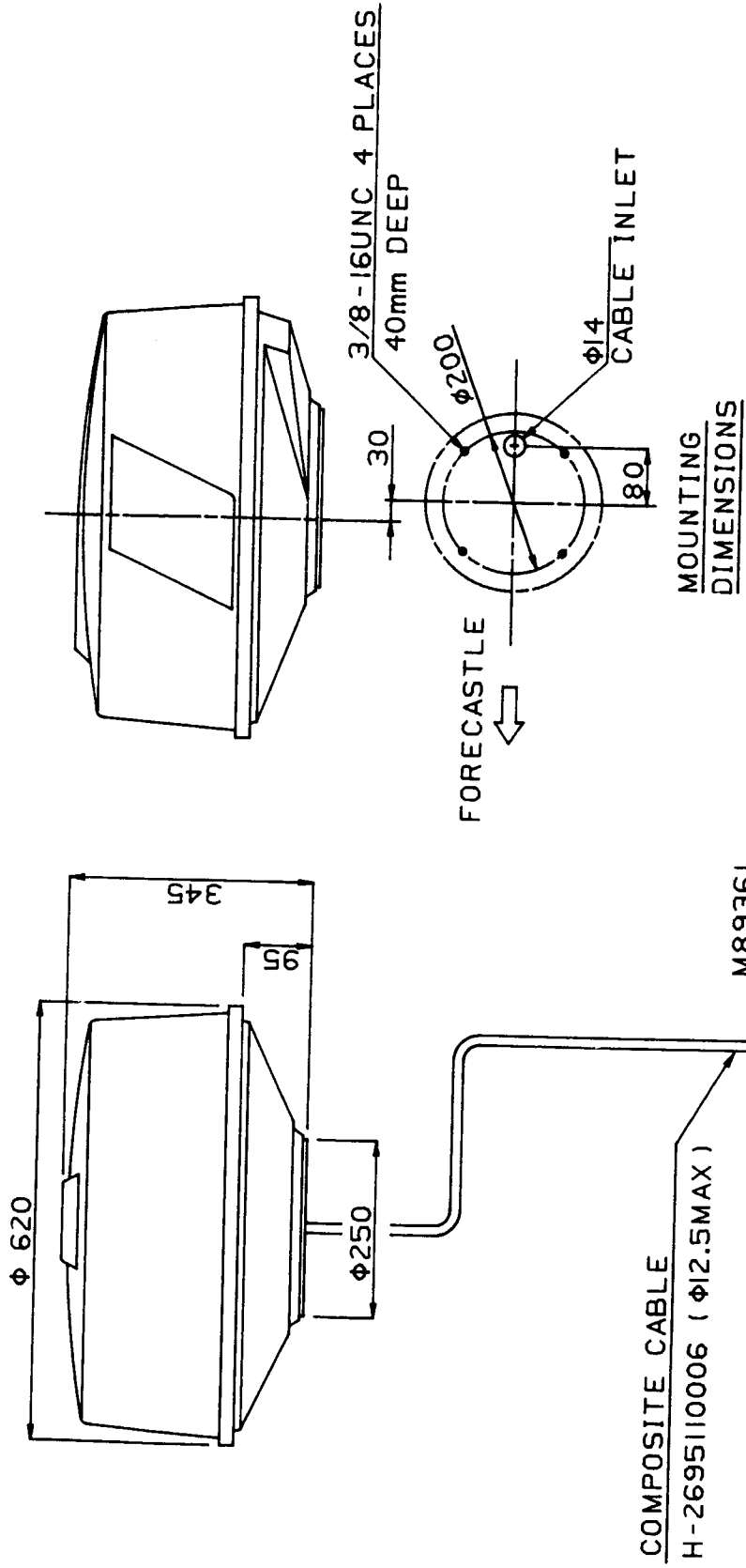

M89361
DISPLAY UNIT
WEIGHT APPROX. 7.5 kg

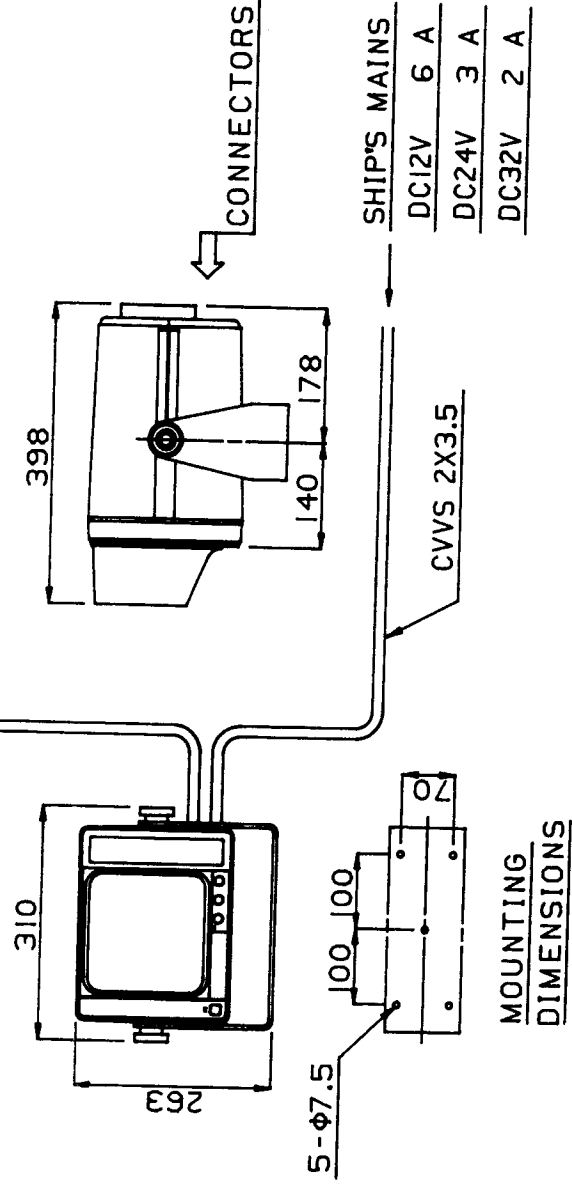

NOTES: 1. THE DISTANCE BETWEEN THE UNITS AS FOLLOWS.

2. ELIMINATING THE INTERFERENCE ON FREQUENCIES USED FOR MARINE COMMUNICATIONS AND NAVIGATION DUE TO OPERATION OF THE RADAR. ALL CABLES OF RADAR ARE TO BE RUN AWAY FROM THE CABLES OF RADIO EQUIPMENT (EX. RADIOTELEPHONE, COMMUNICATIONS RECEIVER AND DIRECTION FINDER ETC.). ESPECIALLY INTER-WIRING CABLES BETWEEN SCANNER UNIT AND DISPLAY UNIT OF THE RADAR SHOULD NOT BE RUN PARALLEL WITH THE CABLES OF RADIO EQUIPMENT.

STANDARD	MAXIMUM
10 m	20 m

FIG. 101 GENERAL SYSTEM OF 1200 RADAR

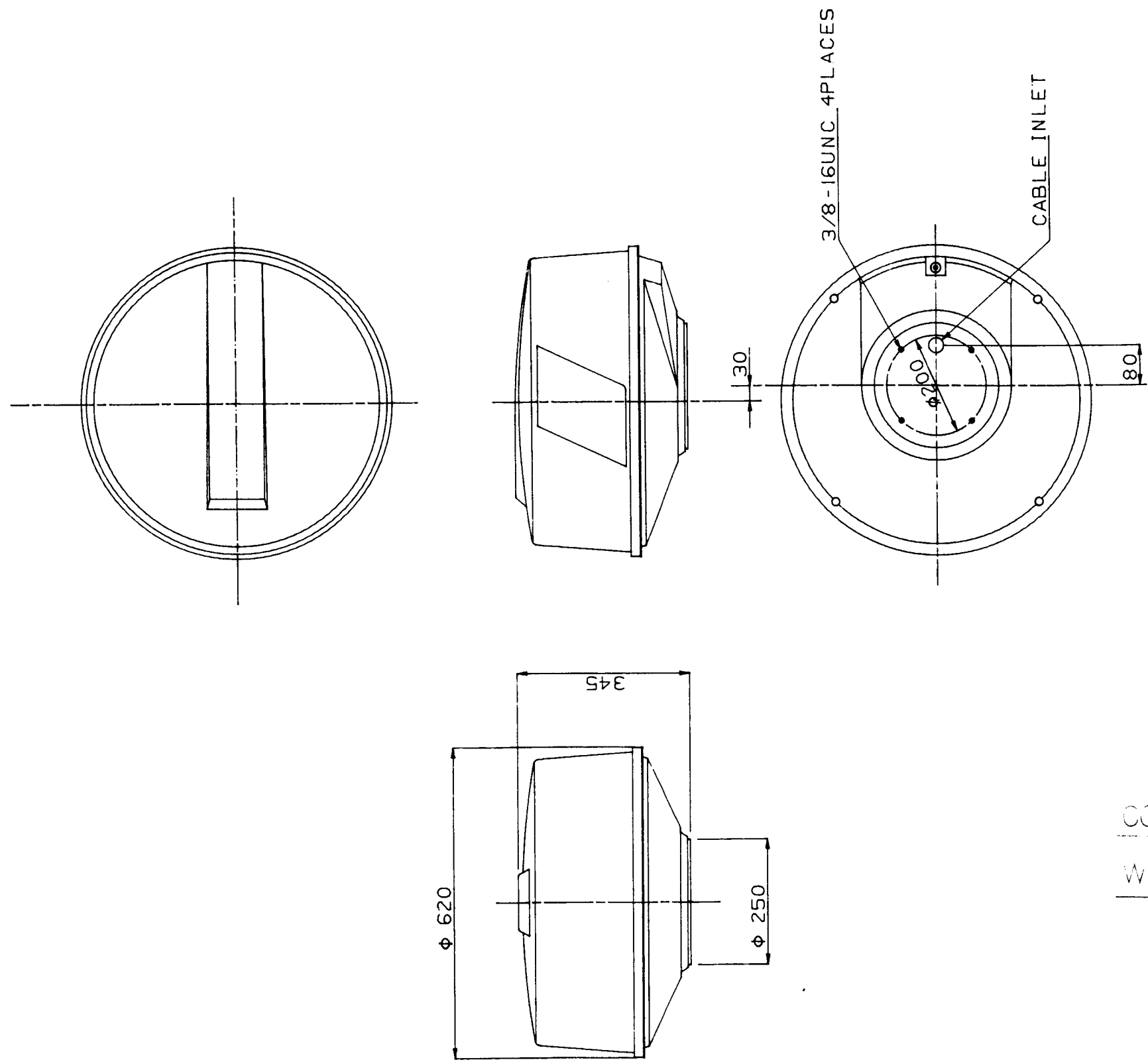

UNLESS OTHERWISE SPECIFIED

DIMENSION SPECIFIED	TOLERANCE
0 TO 10	± 1
OVER 10 TO 50	± 2
OVER 50 TO 100	± 4
OVER 100 TO 200	± 6
OVER 200 TO 500	± 12

COLOR WHITE
 WEIGHT APPROX. 9.5 kg

FIG. 102 OUTLINE DRAWING OF M89362 SCANNER UNIT

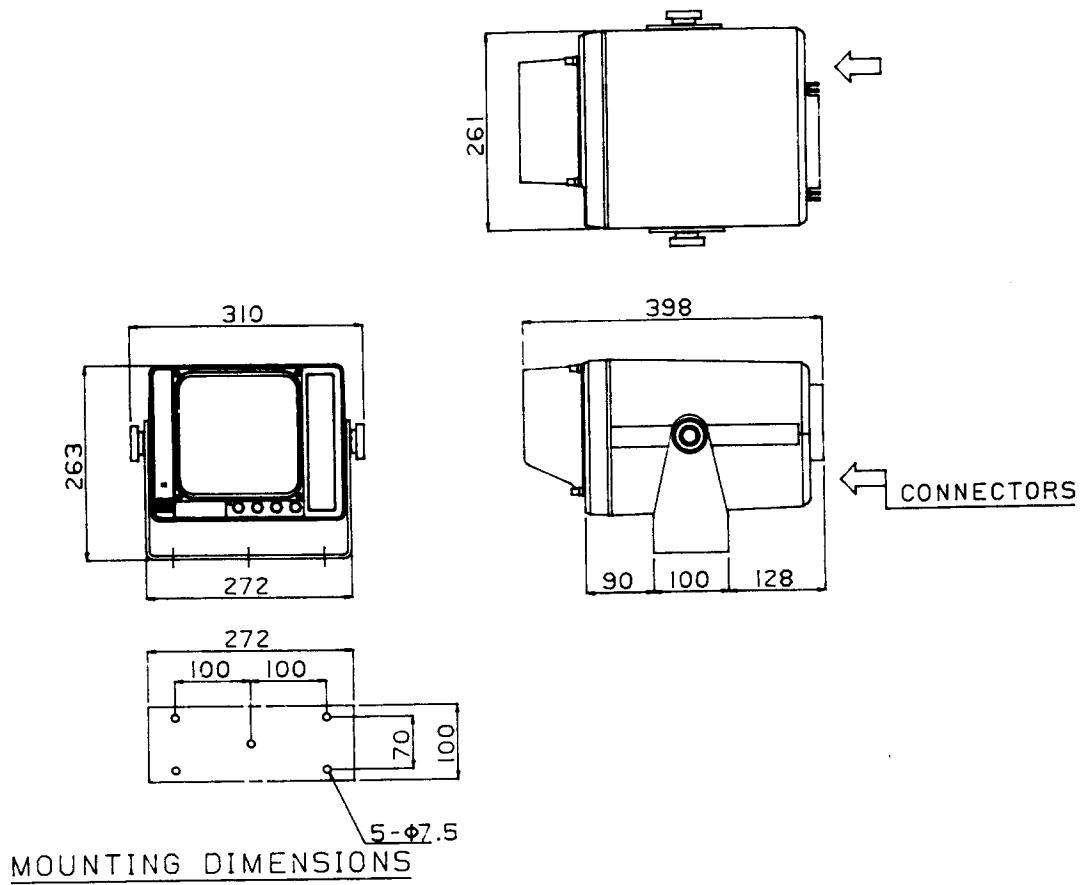

NO.	DESCRIPTION	SPECIFIED
1	DISPLAY UNIT	1
2	BEZEL	1
3	COVER	1
4	HOOD	1
5	CONNECTOR	1
6	OVER 1000 TO 1000	1

COLOR	BEZEL, HOOD	MUNSELL 5GY 6/1
	COVER	MUNSELL 5GY 8/1

WEIGHT APPROX. 7.5 kg

FIG. 103 OUTLINE DRAWING OF M89361 DISPLAY UNIT

M 8 9 3 6 1 DISPLAY UNIT

M 8 9 3 6 2 SCANNER UNIT

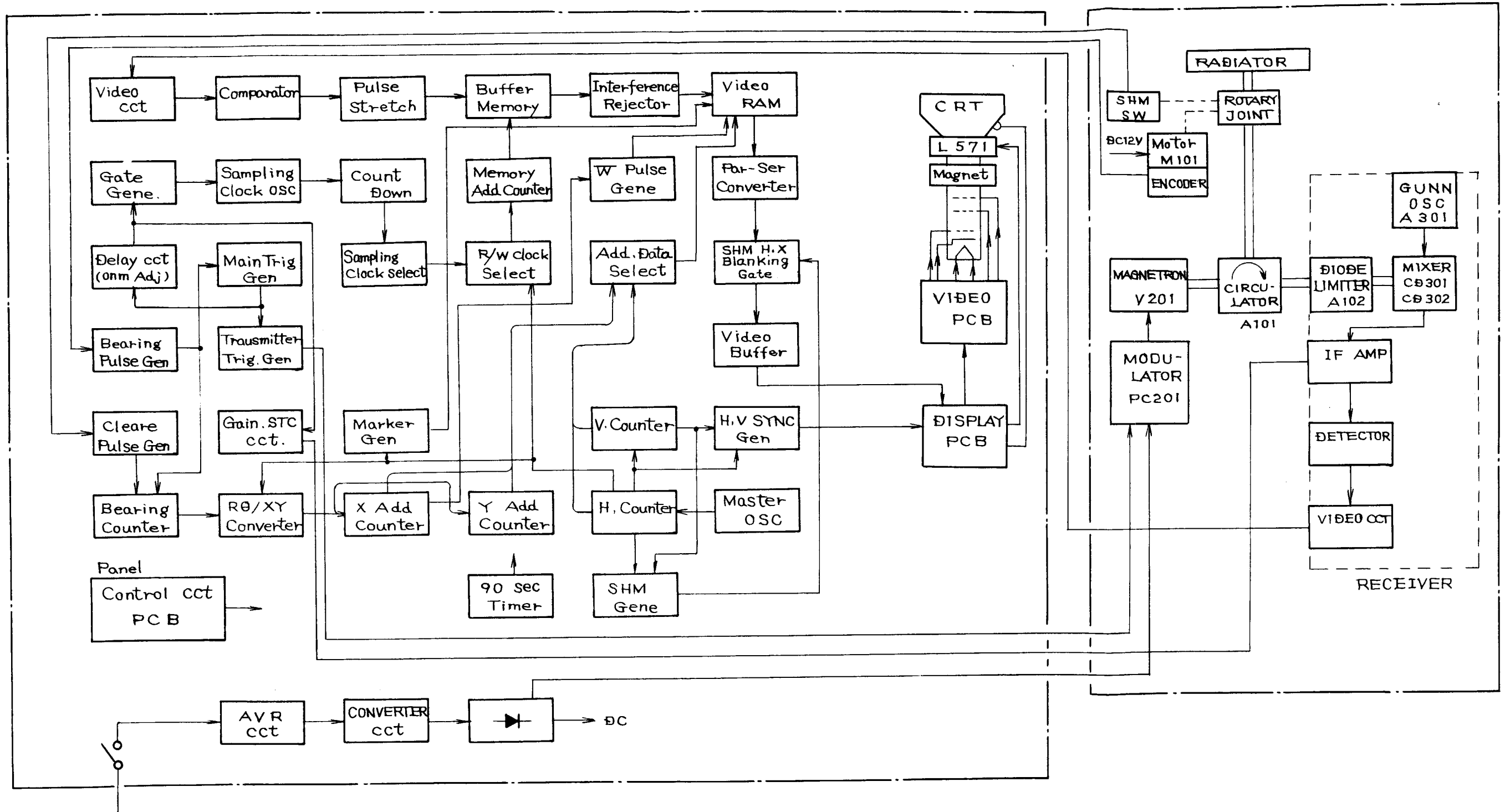

SHIP'S MAINS
DC: 12, 24, 32V

FIG. 104 BLOCK DIAGRAM OF 1200 RADAR

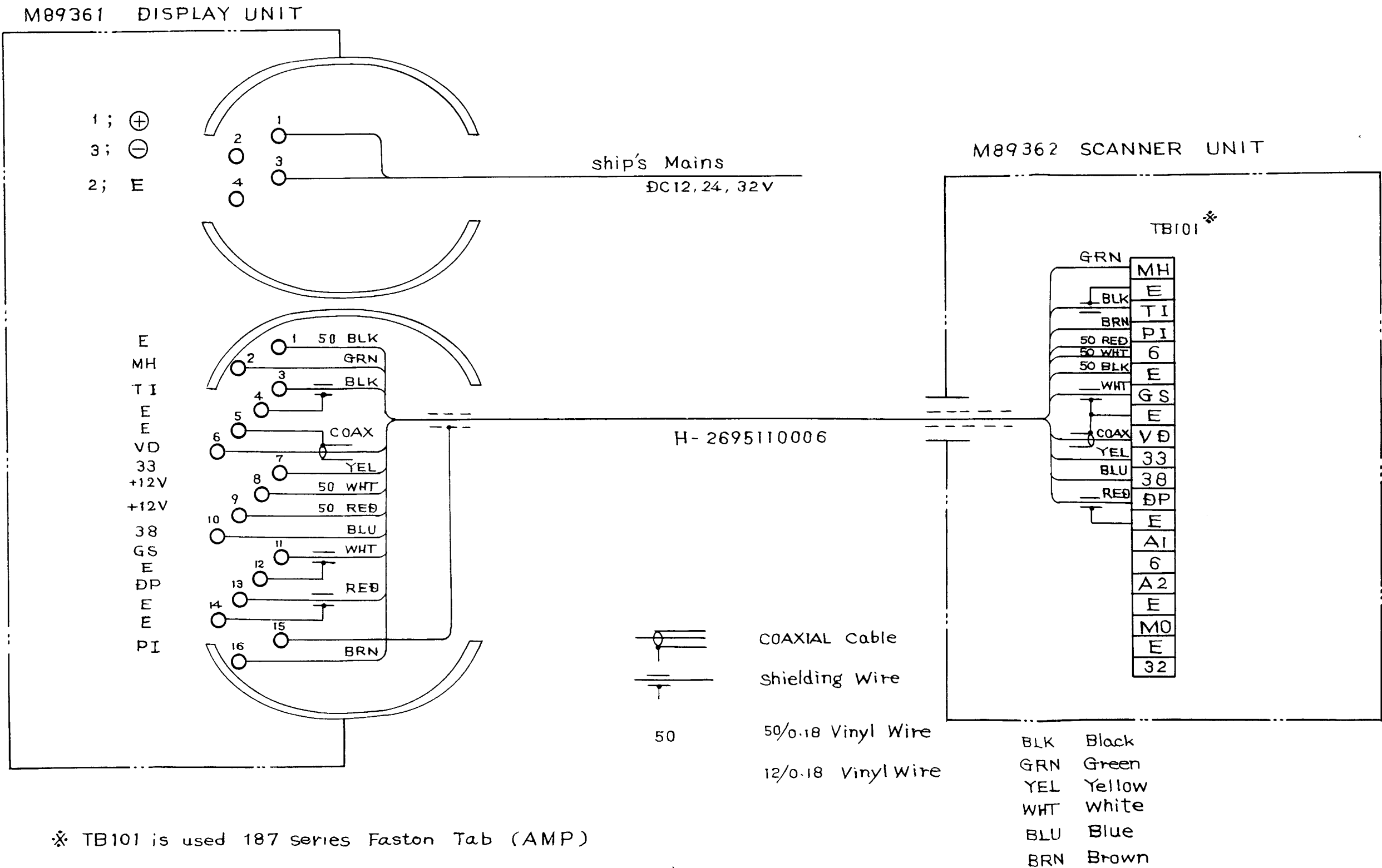

* TB101 is used 187 series Faston Tab (AMP)

FIG. 105 INTERCONNECTIONS OF 1200 RADAR

M839361 DISPLAY UNIT

M89362 SCANNER UNIT

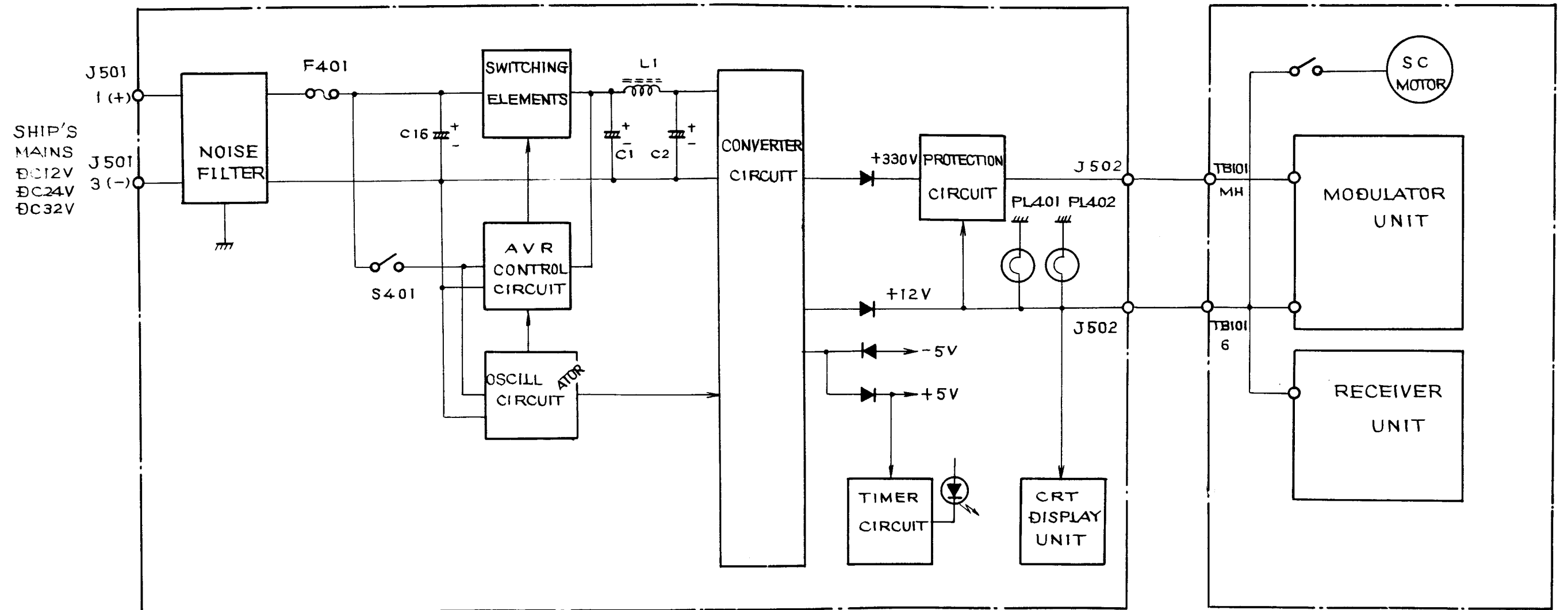

FIG. 106 POWER SUPPLY DIAGRAM OF 1200 RADAR

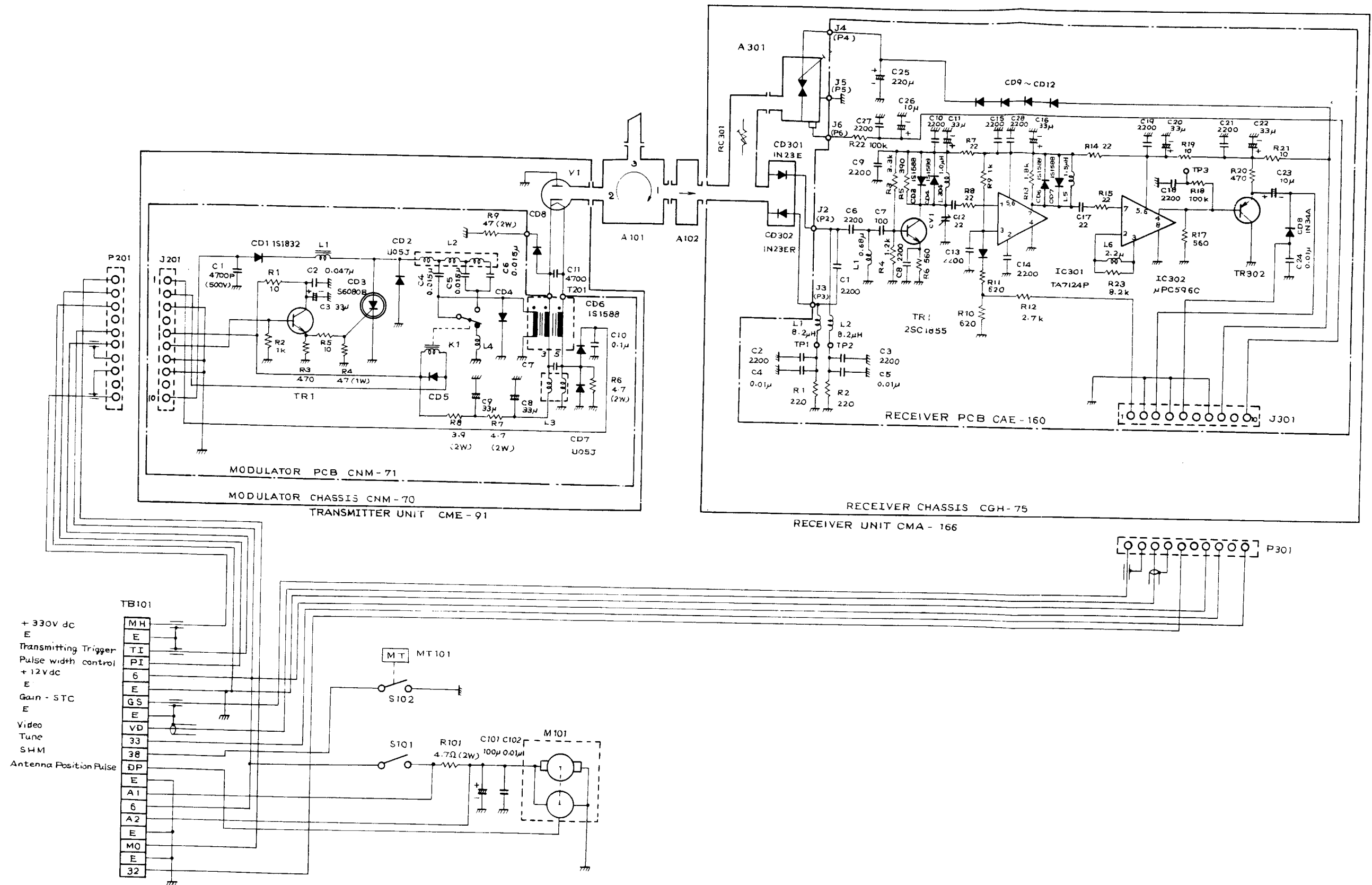

FIG. 107 CIRCUIT DRAWING OF M89362 SCANNER UNIT

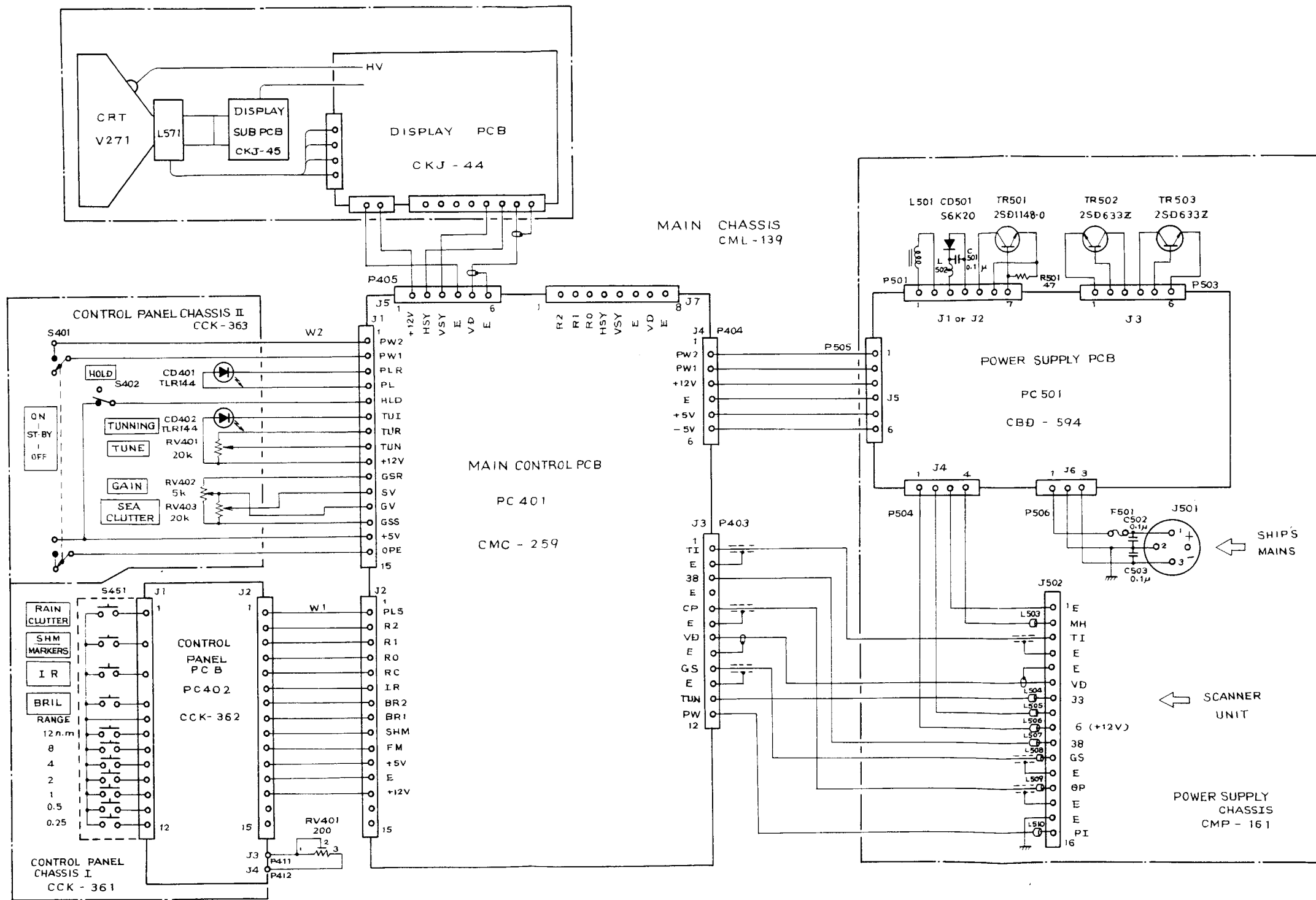
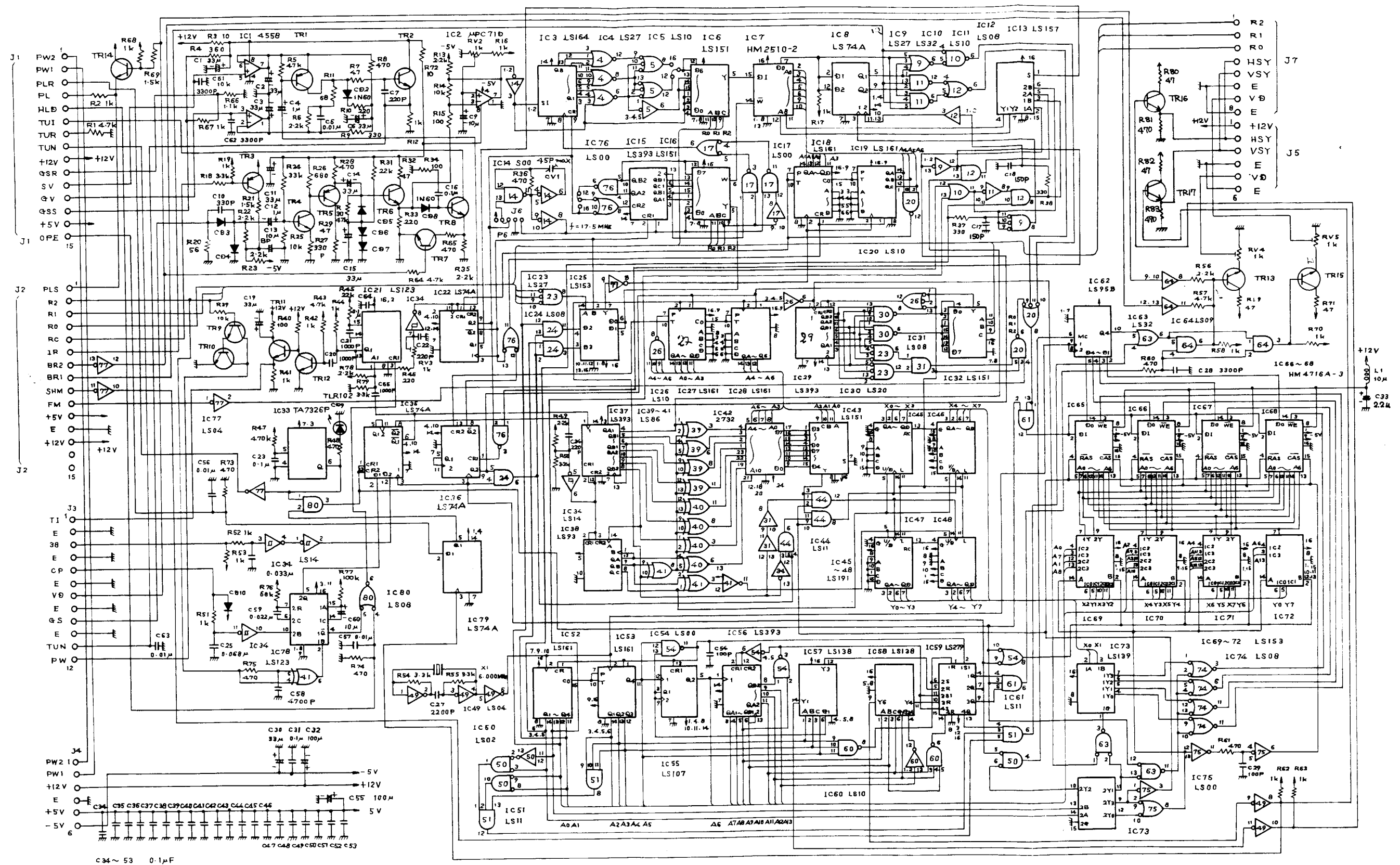

FIG. 108 INTERNAL CONNECTION OF M89361 DISPLAY UNIT



Note; TR1, 3, 5 are 2SA1015-Y
 TR2, 4, 6 ~ 14 are 2SC1815-Y
 All diodes are in 1S1588 unless otherwise specified.

CMC-259

FIG. 109 CIRCUIT DRAWING OF MAIN CONTROL PCB BUILT-IN DISPLAY UNIT

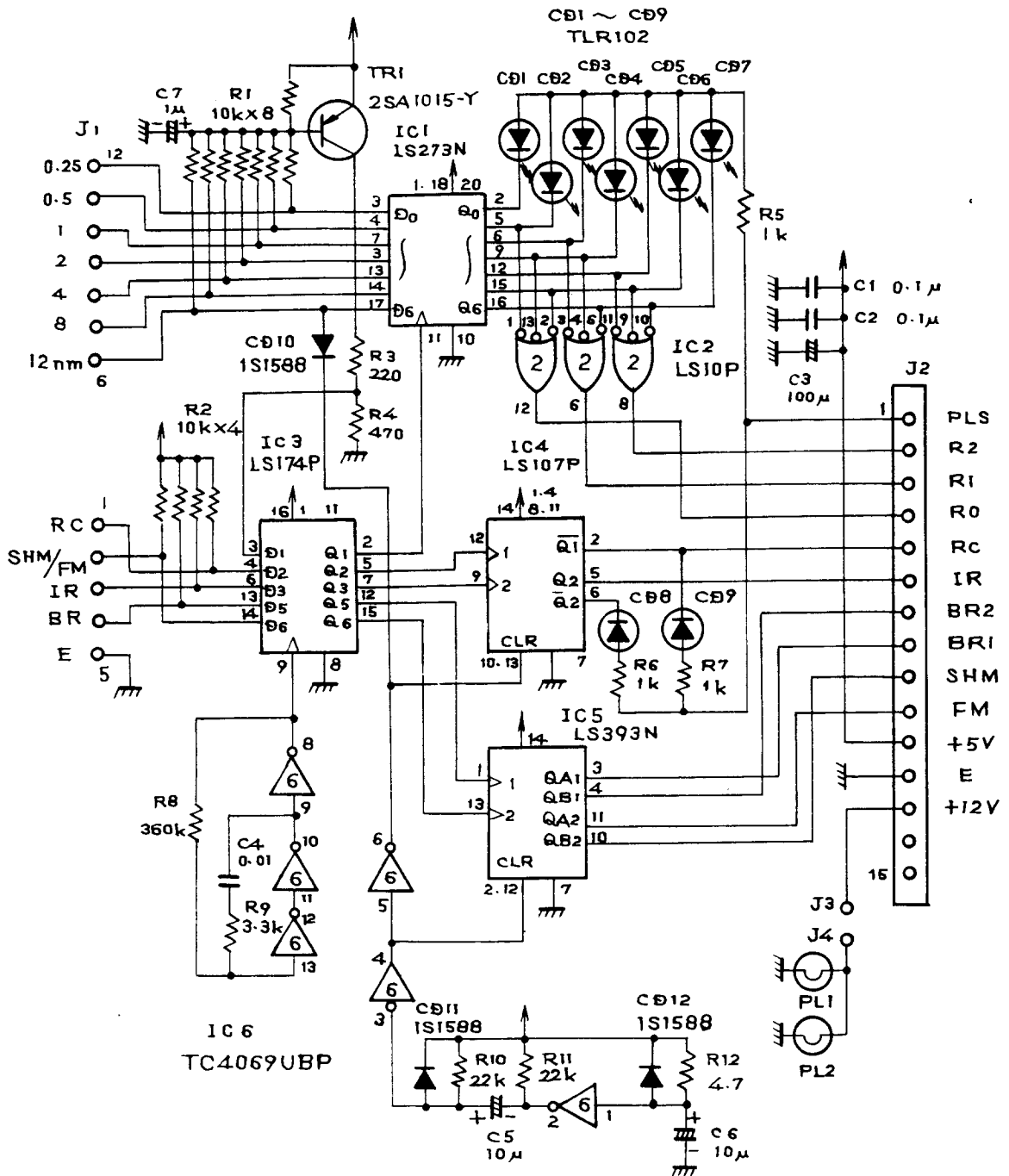

CCK-362

FIG. 110 CIRCUIT DRAWING OF CONTROL PANEL PCB BUILT-IN DISPLAY UNIT

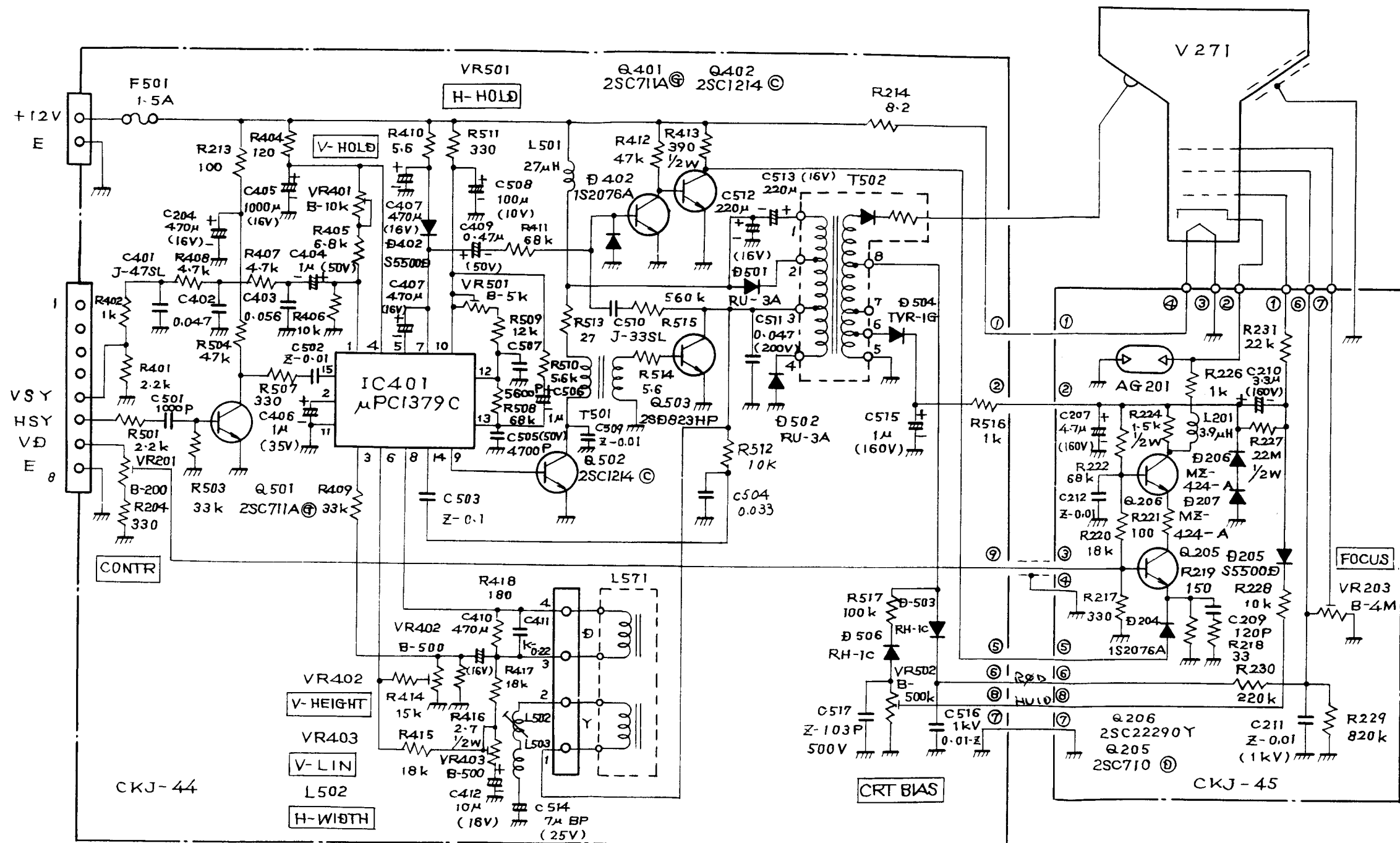
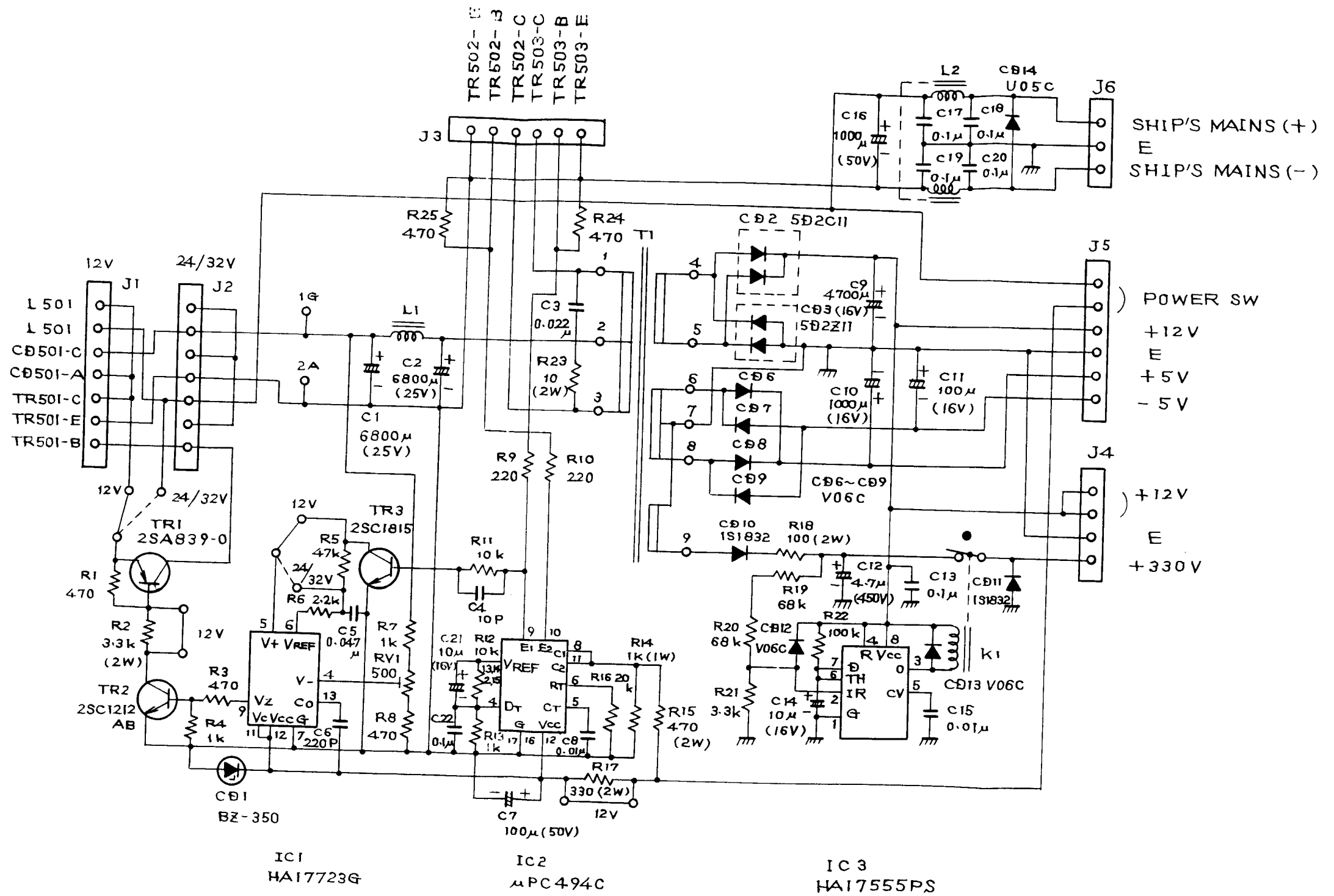

FIG. 111 CIRCUIT DRAWING OF DISPLAY ASSEMBLY BUILT-IN DISPLAY UNIT



CØ-594

FIG. 112 CIRCUIT DRAWING OF POWER SUPPLY PCB BUILT-IN DISPLAY UNIT

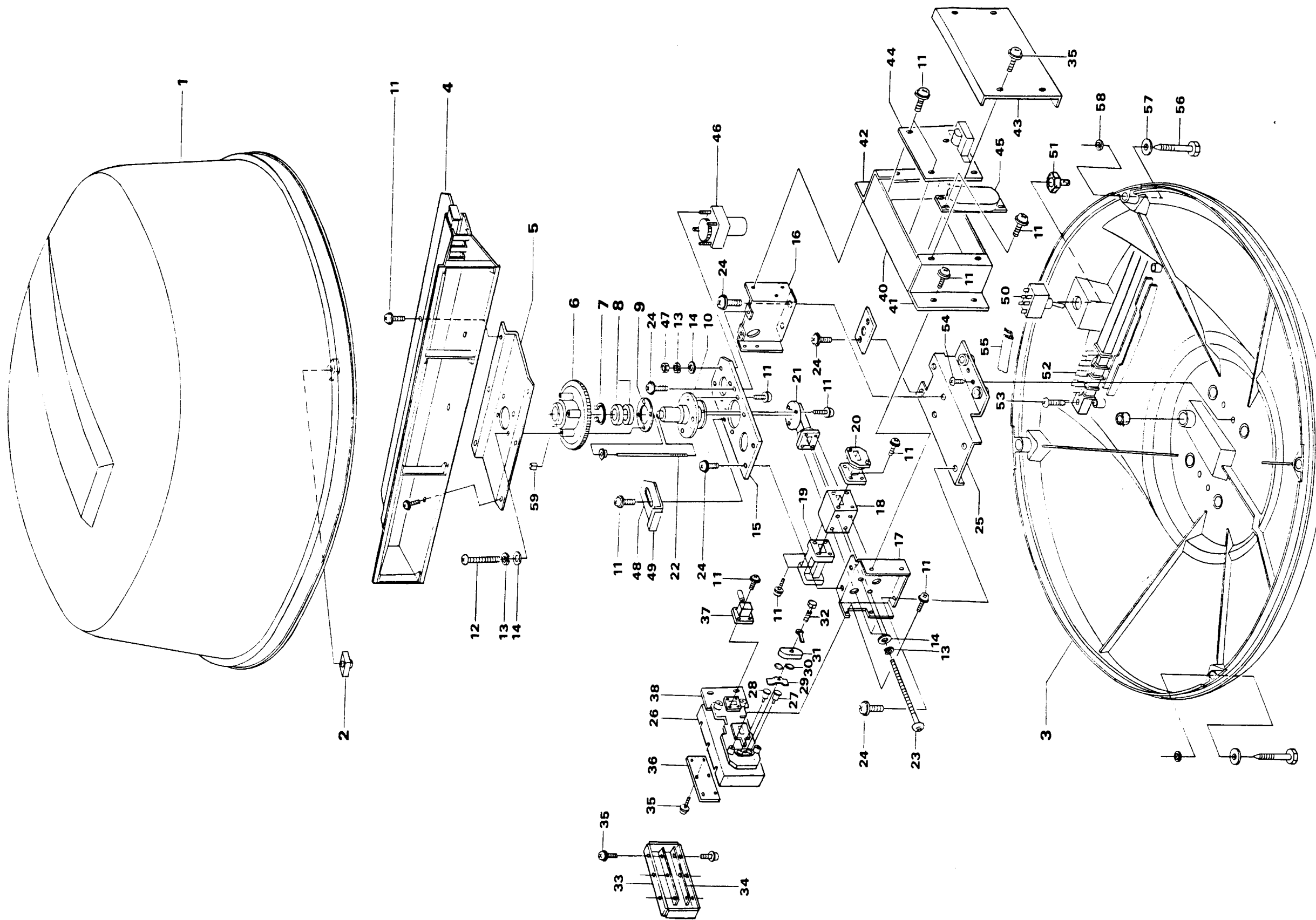

FIG. 113 ASSEMBLY DRAWING OF M89362 SCANNER UNIT

PART LIST 7-17

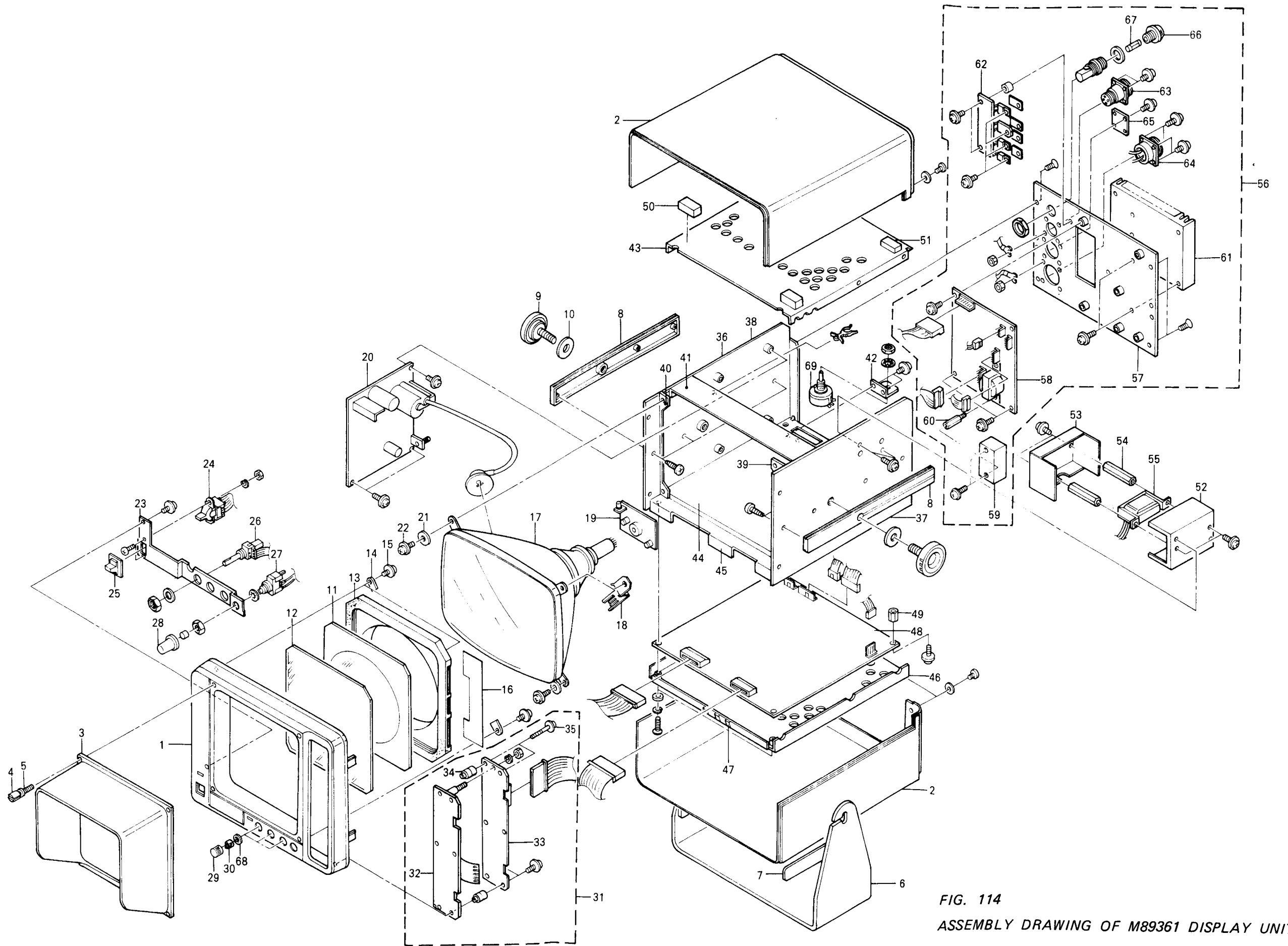

FIG. 114
 ASSEMBLY DRAWING OF M89361 DISPLAY UNIT